

# Faunamaster®

FLAIL MOWER



## Operator's manual

Engine-powered ATV Compatible · FM130



Please carefully read this manual and follow all the instructions. Failure to comply with the warnings and precautions may result in serious injury or death.

# Table of Content

<b><i>SAFETY PRECAUTIONS</i></b>	<b>2</b>
Safety Always Comes First	2
General Safety	2
Motorized machine safety	3
Operating Safety	3
Maintenance Safety	3
Storage & Transport Safety	4
Environment Protection	4
Safety Signs and Model Decals	5
Safety signs	5
Implement decals	6
<b><i>PRODUCT SPECIFICATION</i></b>	<b>7</b>
Implement Specification	7
Implement Identification	8
<b><i>UNPACKING</i></b>	<b>8</b>
<b><i>Product Overview</i></b>	<b>9</b>
<b><i>ASSEMBLY &amp; SET-UP</i></b>	<b>10</b>
Install the Drawbar	10
Attaching the Implement	11
<b><i>OPERATION</i></b>	<b>12</b>
Check-list Before Operation	12
Drawbar Offsetting	12
Tire Height Adjustment	13
Drive Belt Adjustment	13
Battery Voltage Measurement	18
Battery Related Precautions	19
Starting	14
Stopping	15
<b><i>Service and maintenance</i></b>	<b>16</b>
General Maintenance	16
Tightening Torque	17
Flails Replacement	18
Lubrication Points	18
<b><i>STORAGE &amp; Transport</i></b>	<b>19</b>
Storage	20
Transport	20
<b><i>Troubleshooting</i></b>	<b>20</b>
<b><i>Exploded Views &amp; Parts List</i></b>	<b>21</b>
<b><i>WARRANTY</i></b>	<b>50</b>

# Safety precautions

## Safety Always Comes First

Please be fully aware that YOU are responsible for the SAFE operation and maintenance of your flail mower. YOU must ensure that you and anyone else who is going to operate, maintain or work around the flail mower is familiar with the operating and maintenance procedures and related SAFETY information contained in this manual. This manual is prepared to guide you through all essential operations related to this flail mower and alert you to all good safety practices that should be strictly followed.

Please constantly bear in mind that good safety practices not only protect you but also the people around you. Incorporate these practices an inseparable part into your safety program. Be certain that EVERYONE operating this equipment is familiar with the recommended operating and maintenance procedures and follows all the safety precautions. Most accidents can be prevented. Do not risk injury or even death by ignoring good safety practices.

## General Safety

1. Read the Operator's Manual and all safety signs carefully before operating, maintaining, adjusting or removing the flail mower.
2. Do not allow any passenger to ride on the flail mower.
3. Operate only at safe distance from bystanders. Clear the area of people, especially small children, before starting the flail mower.
4. Keep feet and hands from under flail mower at all times. Do not stay between the towing vehicle and the flail mower. Do not approach the flail mower until all motion has stopped.
5. Keep all protective shields in place. If shield removal becomes necessary for repairs, replace the shield prior to use.
6. All rotary blades have the ability to discharge objects at high speeds, which could result in serious injury to bystanders or passers-by. Do use with extreme caution.
7. Place all controls in neutral, stop engine, set park brake, remove ignition key and wait for all moving parts to stop before servicing, adjusting, repairing, attaching or removing.
8. Review safety related items annually with all personnel who will operate or maintain the flail mower.
9. Never start or operate machine unless sitting on the driver's seat.
10. Do not operate mower if you feel unwell or physically unfit, in which case you should stop working.
11. This machine was designed with safety precautions fully considered. However, there is no real substitute for caution and attention in preventing accidents.
12. Never stretch out the limits of any part of the flail mower.
13. Clear working area of stones, branches or hidden obstacles that might be hooked or snagged, causing injury or damage.
14. Always use suitable protection equipment. Do not wear loose clothing or jewelry while working

with the equipment. Long hair should be tied up when working with equipment that has moving parts. Use protective gloves to avoid the risk of burns if hot surfaces such as exhaust pipes are touched, and to avoid oil and petrol getting in contact with the skin. Ear defenders must be worn whilst the engine is running.

## **Motorized machine safety**

1. Fumes contain toxic substances, so never use the machine in poorly ventilated spaces. Do not run the engine in an enclosed space, as the exhaust fumes contain carbon monoxide, which is lethal if inhaled. The motorized machine must not be used indoors.
2. Risk of burns from touching hot surfaces such as exhaust pipes.
3. Avoid getting petrol/oil on your skin. If this happens, rinse thoroughly with water.
4. Avoid breathing in petrol fumes while re-fuelling. Screw the tank cap on securely.
5. Do not keep fuel or other explosive substances near the work zone when using the machine.
6. Only store fuel in containers intended for this purpose.
7. Re-fuelling is not permitted indoors or when the engine is running.
8. Never use dirty oil or fuel. This can cause serious damage to the engine
9. Never leave the machine with engine running. Turn off the engine when you leave the equipment, even for a short period.
10. Never exceed the maximum driving speed.

## **Operating Safety**

1. Carefully read the safety instructions and the operating manual. Make sure that you understand the safety instructions, the operating manual and warning labels.
2. Do not operate flail mower in the raised position.
3. Objects can be thrown out from under machine with sufficient force to severely injure people. Stay away from machine when it is running. Keep others away.
4. Always know what you are cutting. Never operate the flail mower in an area that has hidden obstacles. Remove sticks, stones, wire or other objects from working area before starting.
5. Carry out a visual inspection of the equipment or product before use. Repair or replace damaged or worn parts to reduce the risk of injury. Grease moving parts and check that all nuts and bolts are tightened.
6. Do not operate the machine if it is vibrating substantially; stop the machine immediately and check the maintenance schedule. Check that all nuts and bolts are tightened.
7. Review safety instructions with all operators annually.

## **Maintenance Safety**

1. Good maintenance is your responsibility. Poor maintenance is an invitation to trouble.
2. Follow good shop practices. Keep service area clean and dry.
3. Be sure electrical outlets and tools are properly grounded. Use adequate light for the job at hand.

4. Before working on this machine, shut off the engine, set the brakes, and remove the ignition key.
5. Never work under the machine unless it is secured by a mechanical stand.
6. Use personal protection devices such as safety goggles, hand gloves and hearing protectors, when performing any service or maintenance work. Use heavy gloves when handling blades.
7. Only use genuine parts for service and maintenance.
8. A fire extinguisher and first aid kit should be kept readily accessible while performing maintenance on this equipment.
9. Periodically tighten all bolts, nuts and screws and check that all pins are properly installed to ensure unit is in a safe condition.
10. When completing a maintenance or service function, make sure all safety shields and devices are installed before placing machine in service.

## Storage & Transport Safety

1. Store the machine in an area away from human activity. Do keep the machine out of the children's reach. Do not permit children to play on or around the stored machine.
2. Store the machine in a dry, level area.
3. Clean grease and oil as required and protect it from the elements.
4. Lights must be used for driving on public roads, both in daylight and in darkness. Mark protruding equipment clearly with additional lights or suitable reflectors. It is important that the equipment is visible if you are driving on a public road. These indicators must be correctly mounted,
5. Always follow traffic safety rules on public roads, and following the regulations applying to driving a trailer with towed equipment on a public road.
6. Observers must not lean against or climb onto the machine during transport or during work. NEVER allow anyone to travel on the machine!
7. The maximum transportation speed must not exceed 20 km/h.











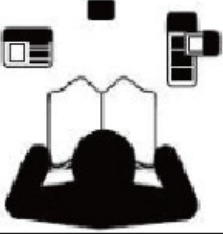
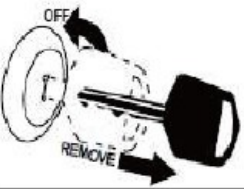
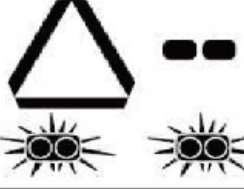

## Environment Protection

1. Disposal of oil and other waste
2. Improper disposal of oil or other waste may be hazardous to the environment.
3. When oil is emptied from the machine, it must be poured into a leak-proof container suitable for oil. It is not permissible to store oil in a container used for food or drink, in order to avoid the oil being consumed by mistake and causing serious injury. It is prohibited to spill oil on the ground, or pour it into a drain or anywhere leading to a water source.
4. Discarded oil, fuel, coolant, brake fluid, filters and batteries may not be thrown away or emptied in just any way. Contact your local authority for further information.



# Safety Signs and Model Decals

## Safety signs





<p><b>For Your Protection</b></p> <ul style="list-style-type: none"> <li>▲ Thoroughly read and understand the Safety Symbols and read all the instructions noted on them.</li> </ul> 	<p><b>Shutdown and Storage</b></p> <ul style="list-style-type: none"> <li>▲ Lower machine to ground, put tractor in Park, turn off the engine, and remove the key.</li> <li>▲ Detach and store implement in an area where children normally do not play. Secure implement by using blocks and supports.</li> </ul> 	<p><b>Use Safety Lights &amp; Devices</b></p> <ul style="list-style-type: none"> <li>▲ Slow moving tractors, self-propelled equipment, and towed implements can create a hazard when driven on public roads. They are difficult to see, especially at night.</li> <li>▲ Flashing warning lights and turn signals are recommended whenever driving on public roads.</li> </ul> 	<p><b>Wear Protective Equipment</b></p> <ul style="list-style-type: none"> <li>▲ Wear protective clothing and equipment appropriate for the job. Avoid loose clothing or hair.</li> <li>▲ Prolonged exposure to loud noise can cause hear impairment or hearing loss. Wear suitable hearing protection such as earmuffs or earplugs.</li> <li>▲ Operating equipment safely requires the full attention of the operator. Avoid wearing radio headphones while operating machinery.</li> </ul> 	<p><b>Practice Safe Maintenance</b></p> <ul style="list-style-type: none"> <li>▲ Understand procedures before doing work. Use proper tools and equipment.</li> <li>▲ Work in a clean and dry area.</li> <li>▲ Lower the implement to the ground, put tractor in park, turn off engine and remove the key before doing the maintenance.</li> <li>▲ Allow the implement to cool completely.</li> <li>▲ Do not grease the implement while it's in operation.</li> <li>▲ Inspect all parts. Make sure all parts are in good shape and installed properly.</li> <li>▲ Remove buildup of grease, oil or debris.</li> <li>▲ Remove all tools and unused parts before operation.</li> </ul> 
<p><b>Tire Safety</b></p> <ul style="list-style-type: none"> <li>▲ Tire chaning can be dangerous and should be performed by trained personnel using the correct tools and equipment.</li> <li>▲ When inflating tires, use a clip-on chuck and extension hose long enough to allow you to stand to one side and NOT in front of or over the tire assembly. Use a safety cage if available.</li> <li>▲ When removing and installing wheels, use wheel handling equipment adequate for the weight load.</li> </ul> 	<p><b>Prepare for Emergencies</b></p> <ul style="list-style-type: none"> <li>▲ Be prepared for fire outbreak</li> <li>▲ Keep a first aid kit and fire extinguisher handy.</li> <li>▲ Keep emergency numbers for doctor, ambulance, hospital and fire department near phone.</li> </ul> 	<p><b>Keep Riders Off Machinery</b></p> <ul style="list-style-type: none"> <li>▲ Riders obstruct the operator's view. They could be struck by foreign objects or thrown from the machine.</li> <li>▲ Never allow children to operate the equipment.</li> </ul> 	<p><b>Avoid HP Fluids Hazard</b></p> <ul style="list-style-type: none"> <li>▲ Escaping fluid under pressure can penetrate the skin causing serious injury.</li> <li>▲ Avoid the hazard by relieving pressure before disconnecting hydraulic lines or performing work on the system.</li> <li>▲ Make sure all hydraulic fluid connections are tight and all hydraulic hoses and lines are in good condition before applying pressure to the system.</li> <li>▲ Use a piece of paper or cardboard, NOT BODY PARTS, to check for suspected leaks.</li> <li>▲ Wear protective gloves and safety glasses or goggles when working with hydraulic systems.</li> <li>▲ If an accident occurs, see a doctor immediately. Any fluid injected into the skin must be treated within a few hours or gangrene may happen.</li> </ul> 	<div style="border: 1px solid black; padding: 5px; text-align: center;">  <b>DANGER</b>              Neglect the safety precautions may cause critical injury or death.         </div> <div style="border: 1px solid black; padding: 5px; text-align: center; margin-top: 10px;">  <b>WARNING</b>              Incorrect operation or service of the machine may cause damage to the machine or serious personal injury.         </div> <div style="border: 1px solid black; padding: 5px; text-align: center; margin-top: 10px;">  <b>CAUTION</b>              Incorrect operation or servicing of         </div>
<p><b>Avoid burns</b></p> <ul style="list-style-type: none"> <li>▲ Never touch the silencer or other part of the exhaust system while the generator is running or when the parts are still hot</li> </ul> 	<p><b>Avoid hearing damage</b></p> <ul style="list-style-type: none"> <li>▲ Long-term exposure to noise can cause permanent hearing damage. Use ear defenders.</li> </ul> 	<p><b>Prevent inhalation of toxic gases</b></p> <ul style="list-style-type: none"> <li>▲ Fumes contain toxic substances, so never use the machine in poorly ventilated spaces. Not for indoor use.</li> </ul> 		



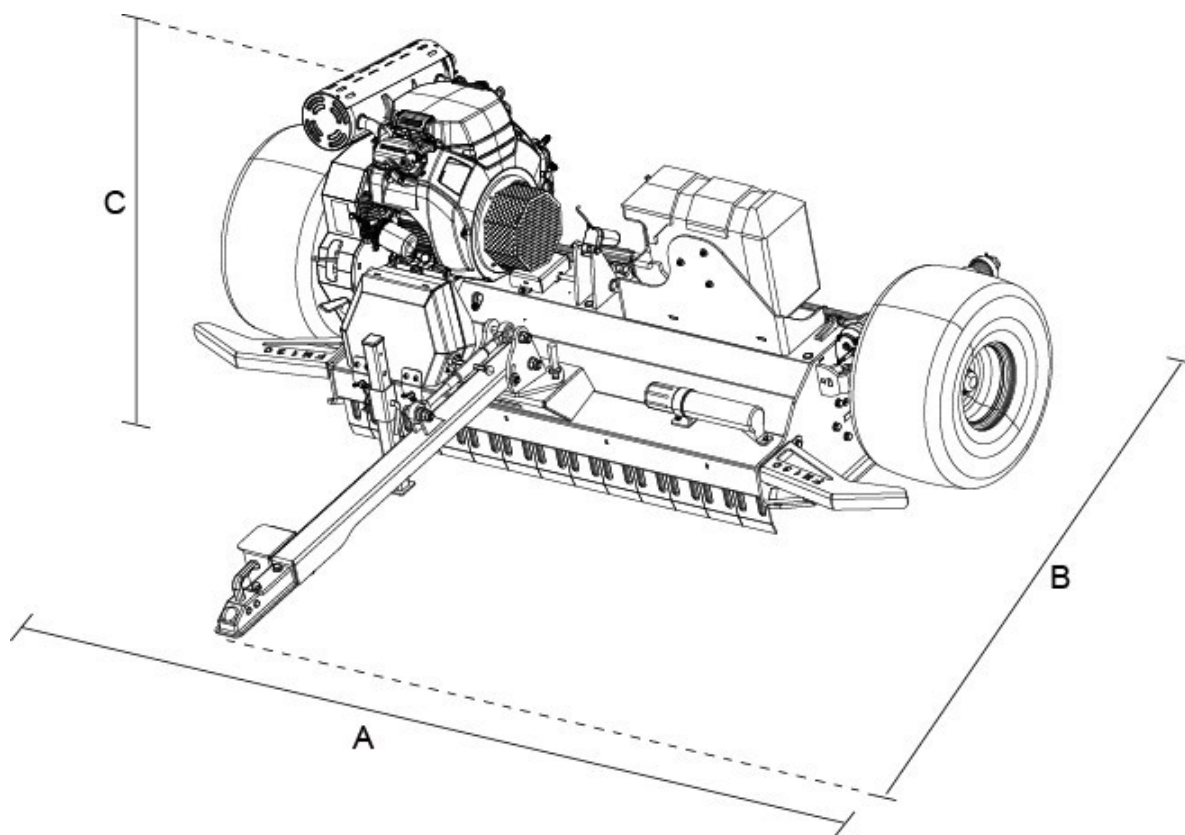



# Product specification

## Implement Specification



Model		FM 130
<b>A</b>	cm	<b>220</b>
<b>B</b>		<b>210</b>
<b>C</b>		<b>111</b>
	cm	<b>130</b>
	HP	<b>25</b>
	RPM	<b>2300</b>
	A (mm)	<b>108</b>
	B (mm)	<b>328</b>

	V (m/s)	40
	N	40
	N	20
	N	3
	Kg	370

## Implement Identification

An Identification plate is affixed to the implement. It contains the “CE” Certification brand and information about: the Manufacturer, Type, Serial Number, Model Number, Weight and Year of Manufacture.

Tårnvej 32, 7200 Grindsted Danmark	<b>Faunamaster</b> 
<b>FLAIL MOWERS</b>	
Model:	EAN:
Serial N.:	Weight:

## Unpacking

### CAUTION

- Upon receipt, check that the machine and its components are not damaged. In the case of damage or missing parts, call the manufacturer or your local dealer to agree upon the procedures to be adopted.
- Wear appropriate personal protective equipment (PPE) that is kept in good condition to protect the hands, feet, head etc. when removing the packaging/crate

**See Figure 1**

**Note:** Depending on the destination, the loading and transport operations can be carried out using different means. The packaging and crating solution used depends entirely on the shipping method chosen and the dimensions of the components packed. When needed, please refer to the exploded views and spare parts list in the end of this manual for proper assembly.

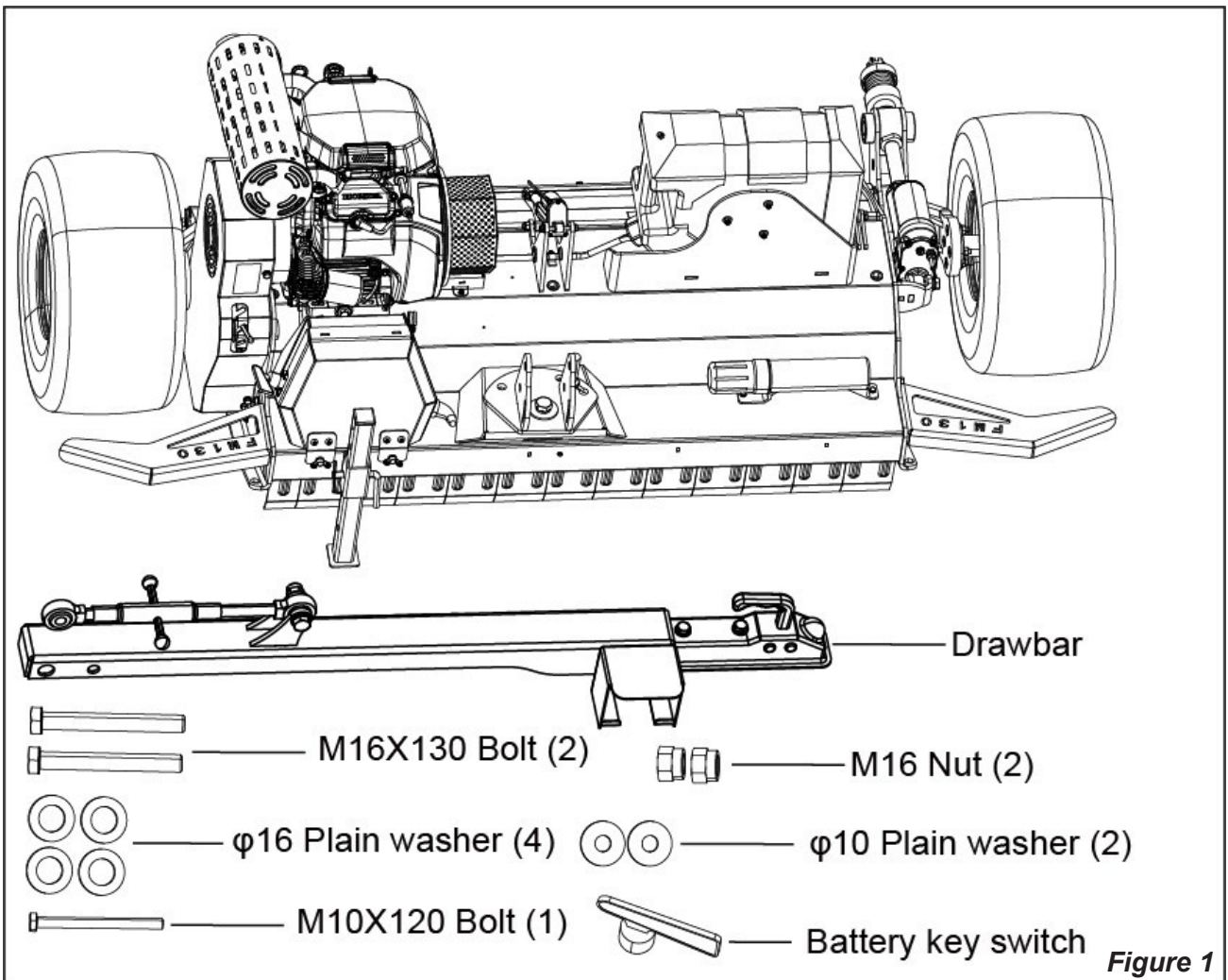

## Product overview

See *Figure 2*

FM130 engine-powered ATV-compatible flail mower provides a compact and versatile solution for efficient land maintenance. This innovative attachment combines the agility of an ATV with the cutting power of a robust flail mower, making it ideal for homeowners, farmers, and land management professionals. With its adjustable cutting heights it can easily accommodate various terrains. The rotating drum with sturdy blades ensures a clean cut while minimizing safety risks. Its compact size and lightweight design enable maneuverability in tight spaces and uneven ground. The digits **130** indicate the cutting width in centimeter.

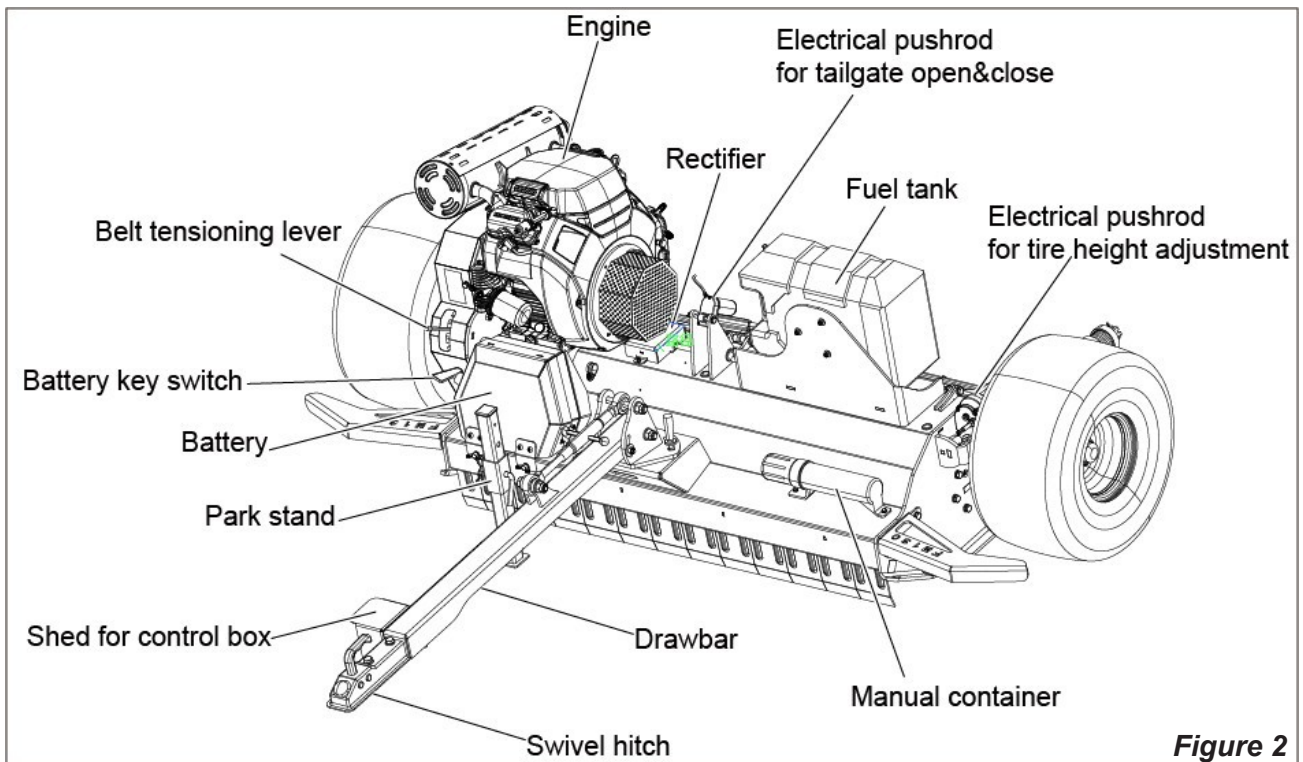

Figure 2

## Assembly & Set-up

### Install the Drawbar

See Figure 3

1. Align the drawbar mounting holes with the holes on the rotating plate bracket;
2. Secure the drawbar with bolts, washers and nuts; tighten to correct torque.

Be aware of fasteners in different sizes use

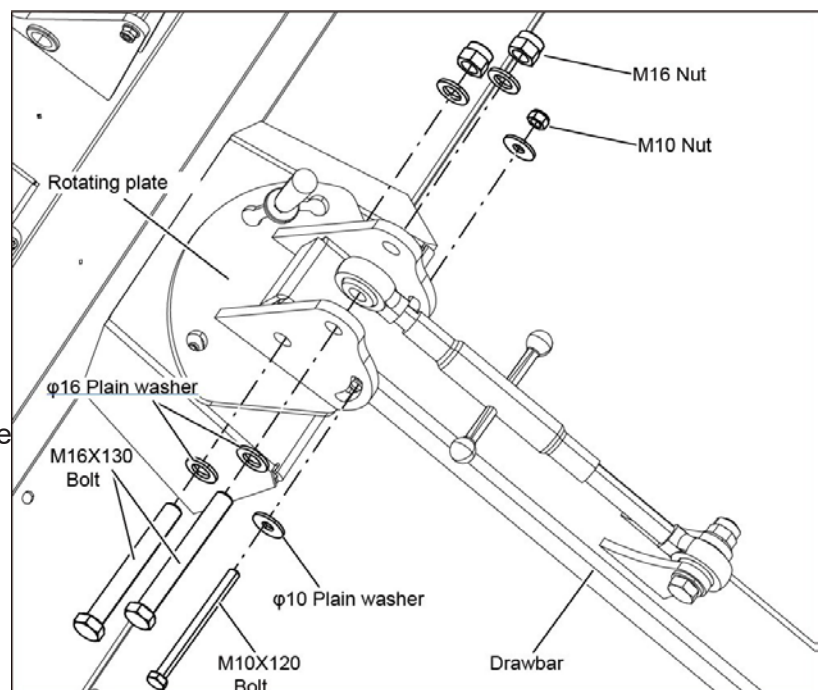

#### **GX690 engine:**

Recommended engine oil: API classification: SJ or above, SAE 10W-30 or 5W-30

Engine oil capacity: 1.5L (No oil filter change)

Engine oil capacity: 1.7L (Oil filter change)

## **WARNING**

Before attachment, ALWAYS ensure the following:

- All safety guards & decals are in good working order and correctly fitted;
- All blades are correctly fitted, undamaged, and not worn to excess
- Lubrication points have been lubricated as per scheduled maintenance period
- The engine oil level is correct & has been maintained as per the handbook; Drive belt(s) are in good working order
- The tires are free of damage and inflated to the correct pressure.

**NOTE:** This machine is designed to attach to the towing vehicle through a swivel hitch.

1. Reverse the towing vehicle up to the machine.
2. Attach the machine onto the towing vehicle's coupling using the auto-lock coupling.  
Ensure the hitch is securely attached to the towing vehicle.

## Tires Overturn Instructions

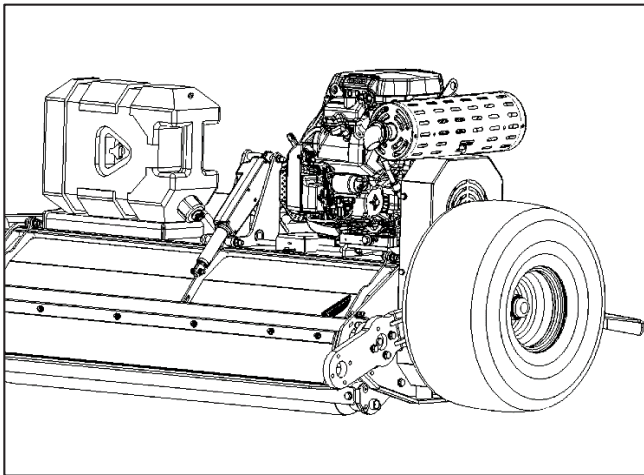

The following tires are on both sides

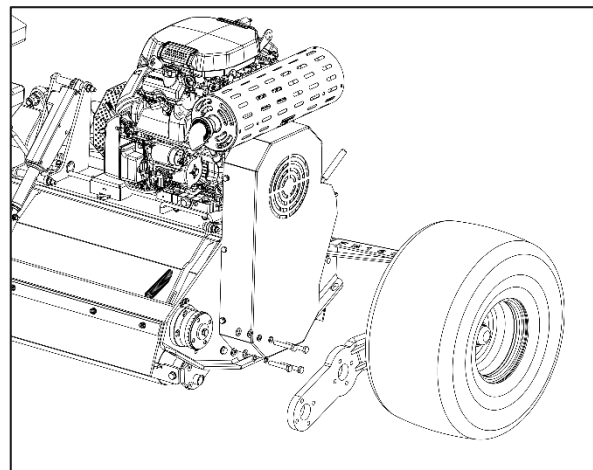

Remove the bolts, remove the tires and adjustment plates

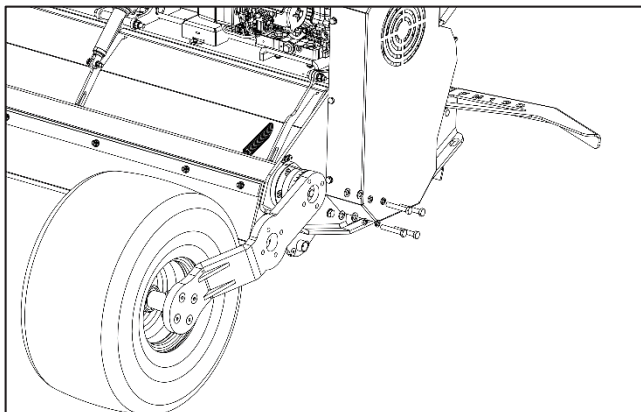

Rotate the tire and adjustment plate at an angle and screw the bolts

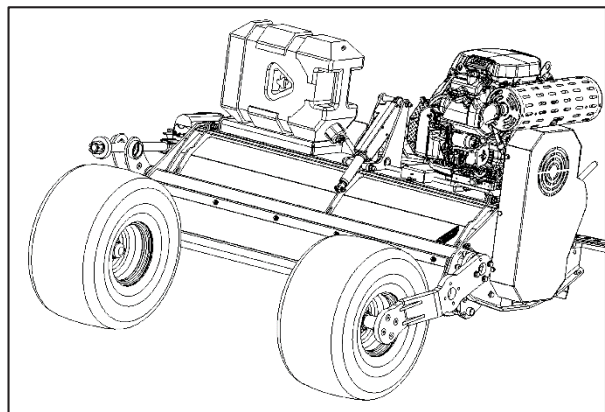

Rear tire installation is complete

# Operation

## Check-list Before Operation

### **WARNING**

- Hazard control and accident prevention are dependent upon the awareness, concern, prudence, and proper training involved in the operation, transport, storage, and maintenance of the mower. Therefore, it is absolutely essential that no one operates the machine without first having read, fully understood, and become totally familiar with the Operator's Manual. Make sure the operator has completed the Checklist below.
- THE MACHINE IS DELIVERED IN ACCOMPANY WITH A SEPARATE ENGINE HANDBOOK, WHERE ALL SAFETY INSTRUCTIONS RELATED TO ENGINE OPERATION AND MAINTENANCE SHOULD BE STRICTLY FOLLOWED.

Before operating the machine, the following should be checked off:

1. Make sure that all nuts, bolts and fittings are securely fixed, and that all packaging materials e.g. wire bands, tape etc. as well as any entangling materials in all rotating parts have been removed.
2. Check the engine oil and petrol in the tank.
3. Before starting up the machine, check and lubricate all grease points on the machine and engine.
4. Use only a towing vehicle with towing capacity within the required limit.
5. Check tire pressure.
6. Check the blades. Be sure they are not damaged or broken and swing freely in their mount. Repair or replace as required.
7. Check and tighten the blade bolts.
8. Install and secure all guards, doors and covers before starting.
9. Before cleaning, repairing and lubricating the machine, stop the engine and make sure all movable parts come to a full stop and allow for adequate time for the machine to cool down.

## Drawbar Offsetting

### CAUTION

- Changing the drawbar angle must be undertaken with the engine switched off & the ignition keys removed. Failure to do so could result in injury or damage to the machine.

The drawbar can be offset to the left or right horizontally as well as be tilted vertically as indicated.

### See Figure 3

1. Pull up and bend the handle of quick fastener 90° downward;
2. Untighten the quick fastener and the bolt collar by turning the handle;
3. Move the drawbar horizontally into the desired location;
4. Push down and tighten the quick fastener and the bolt collar;
5. Lift the handle to be in vertical position.
6. Rotate the tilt lever to incline the drawbar upward or downward for better compatibility with the towing vehicle.

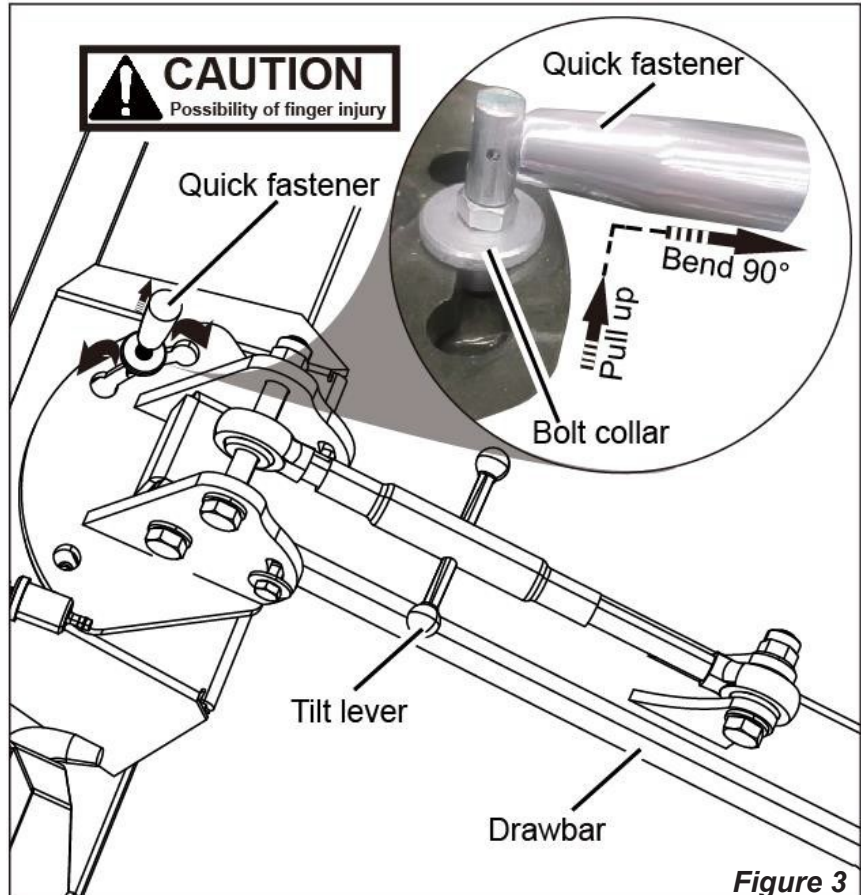

## Adjustment & Control

### DANGER

- In case of mowing overgrown area when the tailgate needs to be opened for more efficient material discharging, it is important to take extra care when operating a flail mower with an open tailgate. By following these precautions, you can help prevent accidents and ensure a safe and efficient mowing experience.
  - Wear proper safety gear such as safety glasses, earplugs, and sturdy workboots.
  - Keep bystanders away from the area as flying debris can cause serious injury or damage.
  - Watch for low-hanging obstacles: An open tailgate makes the machine more susceptible to hitting low-hanging obstacles such as tree branches or overpasses. Be aware of your surroundings and adjust your driving accordingly. Use caution when reversing and avoid sharp turns.

See Figure 4

**Note:** The machine is equipped with electrical control of wheel height adjustment, tailgate open & close as well as engine shutdown. The electrical control is realized by 3 control knobs (A/B/C).

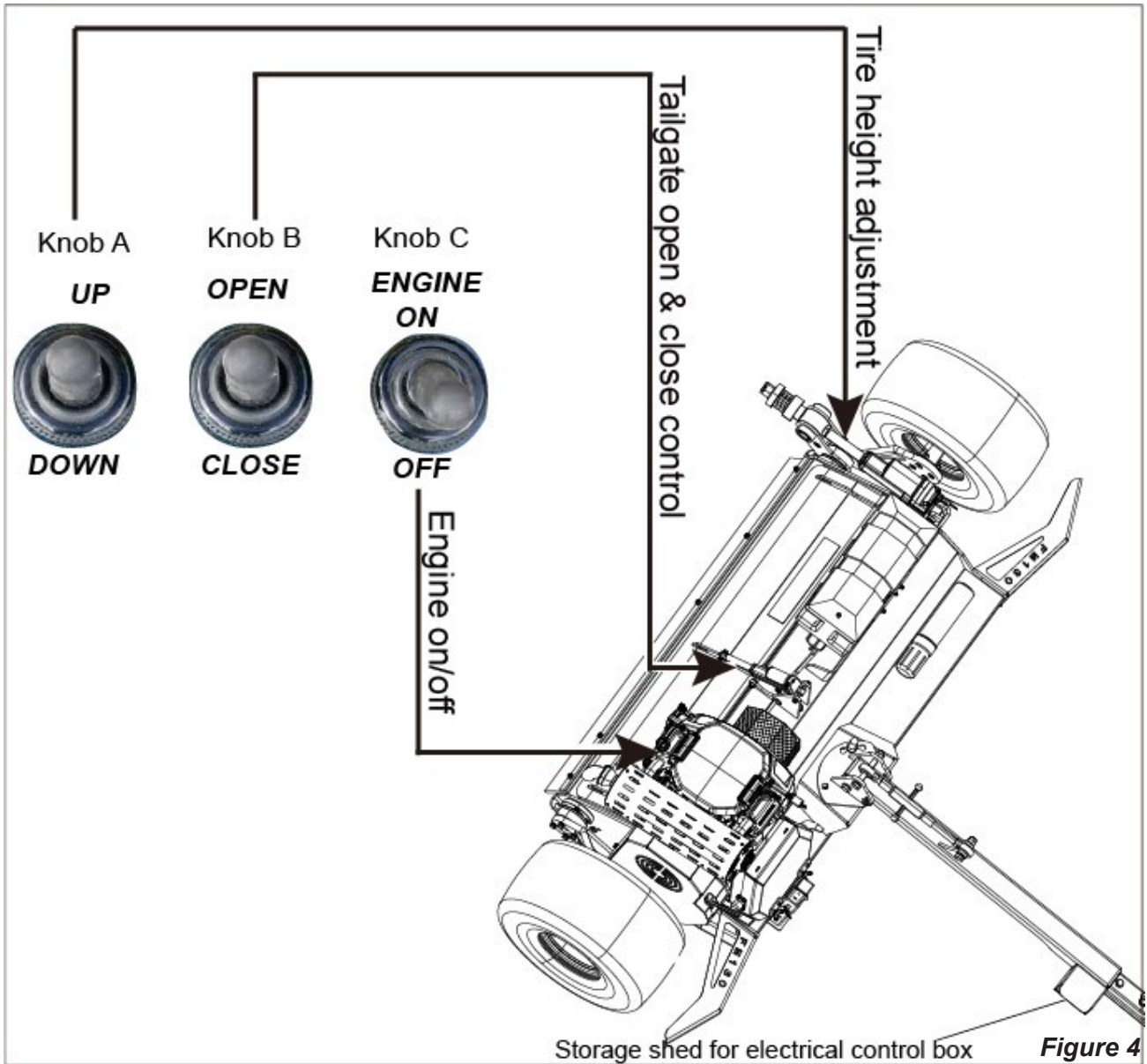

## Drive Belt Adjustment

### **! WARNING**

- Excessive tension on the belt may lead to premature failure of belt and drive components. Excessive tension on the belt may also lead to a safety hazard to the operator or bystanders.

**Note:** The machine is equipped with three drive belts, driven through a centrifugal clutch, with a spring tensioned idler system to compensate for wear of the belts and pulleys. Routine inspection should be carried out on the belts after the first 20 hours of use and every 40 hours thereafter.

### See Figure 5

1. Untighten the bolts and washers to remove the wheel arm together with the tire;
2. Untighten the bolts, spacers and nuts to remove the belt guard;
3. Check belt tension by applying approximately 22 pounds of pressure onto the belt, and the belt should deflect approximately 3/8".
4. If the belt deflection is out of the recommended range, adjust the belt tension by changing the position of the belt tensioning lever. There are 3 positions (indicated in the figure as ①②③) available to choose from in order to achieve desired belt tension.

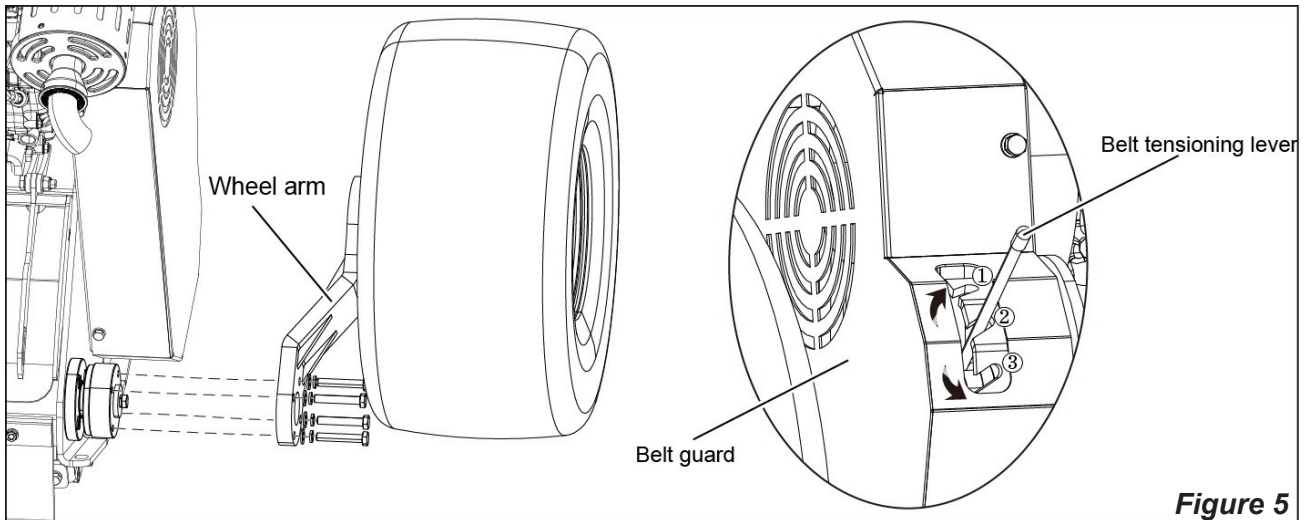

Figure 5

## Starting

### WARNING

- Please refer to the Engine Handbook for all instructions related to engine start-up, operation and stop.
- As the machine is equipped with a centrifugal clutch drive system, the engine must be run at maximum speed **AT ALL TIMES** when cutting.

### See Figure 6

1. Turn on the battery with the key switch;
2. Remotely place Knob C to the **ON** position;
3. To start a cold engine, pull the choke knob out to closed position; to start a warm engine, leave the choke knob in open position;
4. Move the throttle lever away from the MIN. position, about 1/3 of the way toward the MAX. position;
5. Turn the engine switch to the **ON** position, then to the **START** position.
6. Push the throttle lever (N) to the max. position to constantly engage the centrifugal clutch.

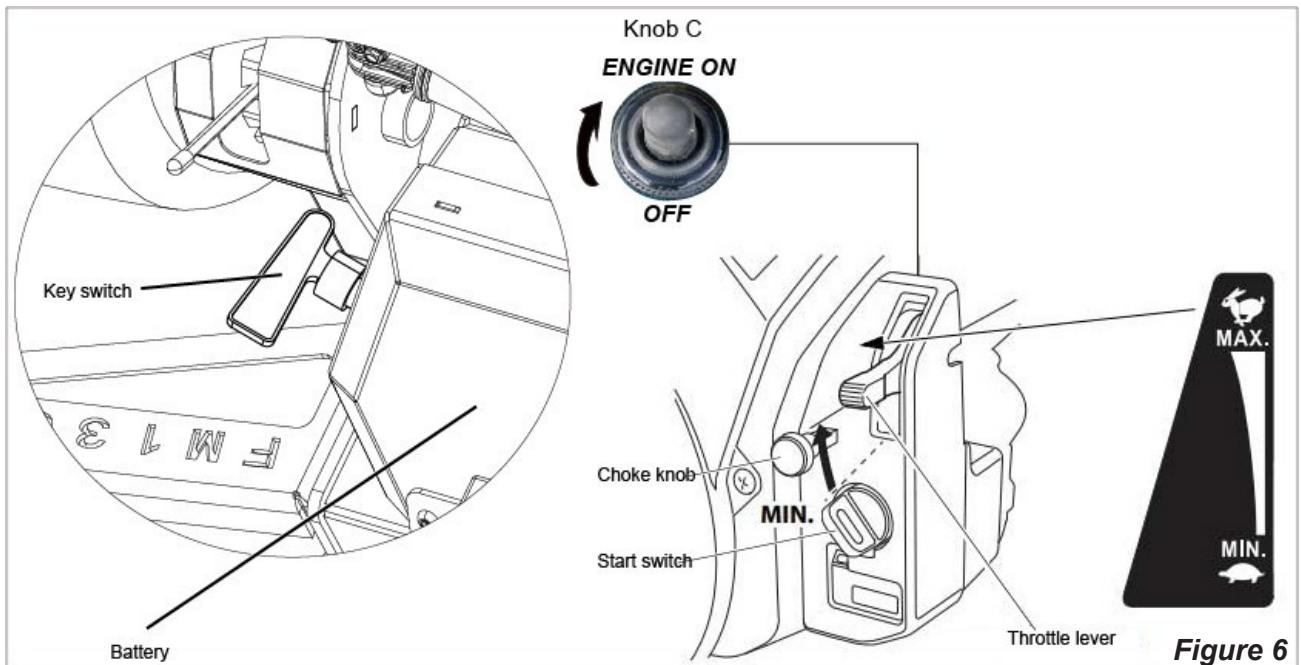

Figure 6

## Stopping

When stopping the mower after a period of heavy use, allow adequate time for the drive belts to cool down. Show caution to hot parts e.g. engine exhaust, belts etc. after engine is switched off.

Ensure the mower drawbar has been adjusted to allow the mower to run directly behind the towing vehicle and is not in an offset position. When the mower has cooled down, ensure all grass has been removed from engine cooling fins, drive belt area, and rotors before operating again.

# Service and Maintenance

## General Maintenance

The period recommended is based on normal operating conditions. Severe or unusual conditions may require more frequent maintenance. Make sure that the equipment is stable and cannot tip over when carrying out maintenance and service work.

1. Replace damaged or worn parts to reduce the risk of injuries.
2. Only use spare parts with equal performance to reduce the risk of injuries and breakdowns.
3. All electrical repairs and electrical connections must be carried out by a qualified person.
4. Check that all nuts and bolts are tightened after maintenance and service work. Always test the machine before starting work.

# Tightening Torque

Please follow the table below to identify the torque value as required.

Torque Values Chart for Common Bolt Sizes													
Bolt Size (inches)	Bolt Head Identification							Bolt Head Identification					
	Grade 2		Grade 5		Grade 8		Bolt Size (Metric)	Class 5.8		Class 8.8		Class 10.9	
in-tpi <sup>1</sup>	N · m <sup>2</sup>	ft-lb <sup>3</sup>	N · m	ft-lb	N · m	ft-lb	mm x pitch <sup>4</sup>	N · m	ft-lb	N · m	ft-lb	N · m	ft-lb
1/4" - 20	7.4	5.6	11	8	16	12	M 5 X 0.8	4	3	6	5	9	7
1/4" - 28	8.5	6	13	10	18	14	M 6 X 1	7	5	11	8	15	11
5/16" - 18	15	11	24	17	33	25	M 8 X 1.25	17	12	26	19	36	27
5/16" - 24	17	13	26	19	37	27	M 8 X 1	18	13	28	21	39	29
3/8" - 16	27	20	42	31	59	44	M10 X 1.5	33	24	52	39	72	53
3/8" - 24	31	22	47	35	67	49	M10 X 0.75	39	29	61	45	85	62
7/16" - 14	43	32	67	49	95	70	M12 X 1.75	58	42	91	67	125	93
7/16" - 20	49	36	75	55	105	78	M12 X 1.5	60	44	95	70	130	97
1/2" - 13	66	49	105	76	145	105	M12 X 1	90	66	105	77	145	105
1/2" - 20	75	55	115	85	165	120	M14 X 2	92	68	145	105	200	150
9/16" - 12	95	70	150	110	210	155	M14 X 1.5	99	73	155	115	215	160
9/16" - 18	105	79	165	120	235	170	M16 X 2	145	105	225	165	315	230
5/8" - 11	130	97	205	150	285	210	M16 X 1.5	155	115	240	180	335	245
5/8" - 18	150	110	230	170	325	240	M18 X 2.5	195	145	310	230	405	300
3/4" - 10	235	170	360	265	510	375	M18 X 1.5	220	165	350	260	485	355
3/4" - 16	260	190	405	295	570	420	M20 X 2.5	280	205	440	325	610	450
7/8" - 9	225	165	585	430	820	605	M20 X 1.5	310	230	650	480	900	665
7/8" - 14	250	185	640	475	905	670	M24 X 3	480	355	760	560	1050	780
1" - 8	340	250	875	645	1230	910	M24 X 2	525	390	830	610	1150	845
1" - 12	370	275	955	705	1350	995	M30 X 3.5	960	705	1510	1120	2100	1550
1-1/8" - 7	480	355	1080	795	1750	1290	M30 X 2	1060	785	1680	1240	2320	1710
1-1/8" - 12	540	395	1210	890	1960	1440	M36 X 3.5	1730	1270	2650	1950	3660	2700
1-1/4" - 7	680	500	1520	1120	2460	1820	M36 X 2	1880	1380	2960	2190	4100	3220
1-1/4" - 12	750	555	1680	1240	2730	2010							
1-3/8" - 6	890	655	1990	1470	3230	2380							
1-3/8" - 12	1010	745	2270	1670	3680	2710							
1-1/2" - 6	1180	870	2640	1950	4290	3160							
1-1/2" - 12	1330	980	2970	2190	4820	3560							

<sup>1</sup> in-tpi = nominal thread diameter in inches-threads per inch  
<sup>2</sup> N · m = newton-meters  
<sup>3</sup> ft-lb = foot pounds  
<sup>4</sup> mm x pitch = nominal thread diameter in millimeters x thread pitch

Torque tolerance + 0%, -15% of torquing values. Unless otherwise specified use torque values listed above.  
 All locknuts or lubricated fasteners: Use 75% of torque value. (i.e. 1/2"-13 GR5 = 76 ft-lb; 75% of 76 or .75 x 76 = 57 ft-lb)

## Flails Replacement



- To avoid serious injury or death, the engine must be turned off, and switch key removed before doing work underneath the machine. Wear heavy gloves and all necessary protections while replacing the flails.

Frequently check the flails to make sure they are in good working condition and properly secured to the rotor. Replace worn or damaged parts with new flails. Make sure that the replacement of blade with the same weight to achieve a balance of rotor spinning. The replaced blade must be the original factory accessories. The machine has a standard configuration of hammer flails, as well as an optional configuration of Y flails.

See **Figure 7**

### Hammer blade installation

1. Untighten the nut;
2. Remove the bolt;
3. Replace the worn-out blade with a new one.
4. Put back the bolt and tighten the nut with required torque.

### Y blade installation

The heavy-duty Y blades have a cutting edge on both the leading and trailing edges. When the leading edge wears out, turn existing pair of blades around 180 degrees and reinstall with new locknuts.

1. Untighten the nut;
2. Remove the bolt and washers;
3. Replace the worn-out blade with new one.

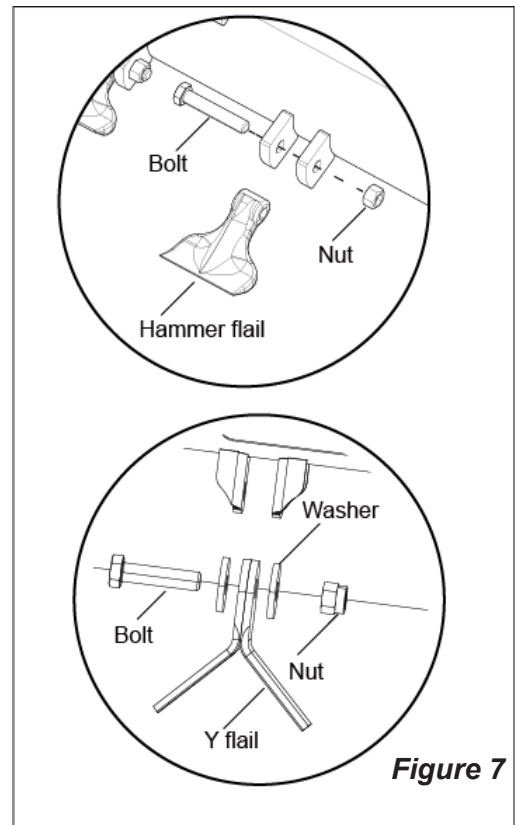

## Lubrication Points



Please use multi-purpose lithium-based grease to lubricate points which are clearly identified with GREASE decal on the machine, mainly for rotor bearing, side belt drive system and rear roller bearing.

## Battery Voltage Measurement

### Measurement indication explanations

- The battery voltage should not be lower than DC12.5V when the battery is not loaded.
- The battery voltage should not be lower than DC11V when the battery is under load.

### Measurement method

- Prepare a digital multimeter (as shown in the figure), insert the red test lead (+) into the VΩ round hole, insert the black test lead ( - ) into the COM round hole, and set the multimeter to DC20V.
- Put the red test lead (+) on the positive electrode of the battery, and the black test lead ( - ) on the negative electrode of the battery to display the value, i.e. the current



voltage of the battery.

- The no-load voltage is measured when there is no load, and the on-load voltage is measured when there is a load.

## Battery Related Precautions

### Battery storage

- If the idle time exceeds one week; the negative wire of the battery manufacturer should be removed.
- If the idle time exceeds one month, the battery should be removed and placed in a dry place, and the temperature should be between 10° and 30°.
- Keep the battery clean and dry.

### Battery removal

- When disconnecting the battery, be sure to disconnect the negative electrode first, and then disconnect the positive electrode;
- When connecting the battery, be sure to connect the positive pole first, and then connect the negative pole;
- Be careful not to reverse and short-circuit the positive and negative poles of the battery;
- Do not put metal or conductive objects on the battery;
- The engine can only be started when the battery connection screws are fastened;
- Do not loosen or remove the connecting screws while the engine is running.

**Battery parameters:** DC12V 22AH;

### Battery charger parameters:

- Input voltage: match according to local voltage feed
- Output voltage: DC13.8---DC14.5V
- Power: 29W--- 40W

# Storage & transport

## Storage

1. Remove any dirt and grease that may have accumulated on the mower and moving parts. Scrape off compacted dirt from under the hood. Clean the machine inside and out so as to avoid corrosion.
2. Check rotor, blades, blade mounts, and blade bolts for wear and replace if necessary.
3. Don't spray water on the rolling bearing if you clean the machine with high pressure sprayer.
4. Refer to Engine Handbook for engine service and maintenance.
5. Recoat the parts rubbed and damaged for anti-corrosion.

## Transport

1. The engine must be stopped and the blades at a standstill before adjusting to the transport position. Never move from one site to another with the engine running.
2. Remove any grass debris from the deck before leaving the field.
3. Please note the machine is not road legal, and should not be used on public roadways.
4. Select a safe ground travel speed when transporting from one area to another. When traveling on roadways, transport in such a way that faster moving vehicles may pass safely.

## Troubleshooting

FAILURE	POSSIBLE CAUSES	SOLUTION
Irregular cut	Worn, bent or broken flails	Check and replace the flails
	Speed too low	Always use max. throttle
	Machine not properly leveled to the ground	Level the machine and check the tire pressure
	Excessive build-up of cuttings	Open the rear flap; reduce the forward speed
Abnormal machine noise	Unbalanced rotor	Check flails & replace any damaged flails.
	Loosen bolts/nuts/fasteners	Tighten the bolts/nuts/fasteners
	Component damage	Check and repair or replace the damaged part
Excessive belt noise	Belt slipping	Adjust the belt tension
	Belt worn-out	Replace the belt
Vibration	Worn, bent or broken flails	Inspect and replace as necessary
	Rotor out of balance	Balance or replace rotor
	Worn rotor bearings	Replace rotor bearings
Excessive movement of drawbar	Loosen fastener	Tighten the fasteners
Bearing overheating	Lack of lubrication	Grease the bearing
	Bearing dirty	Clean the bearing
Belts overheating	Flails in touch with the ground	Raise cutting height
	Working speed too high	Reduce forward speed
	Belt slipping on pulleys	Adjust the belt tension
Engine won't start	Battery key switch not installed	Install the key switch
	Refer to Engine Handbook	
Electrical pushrod won't work	Battery runs out (when engine not working)	Replace the battery

# Exploded views & parts list

## MACHINE BREAK-DOWN

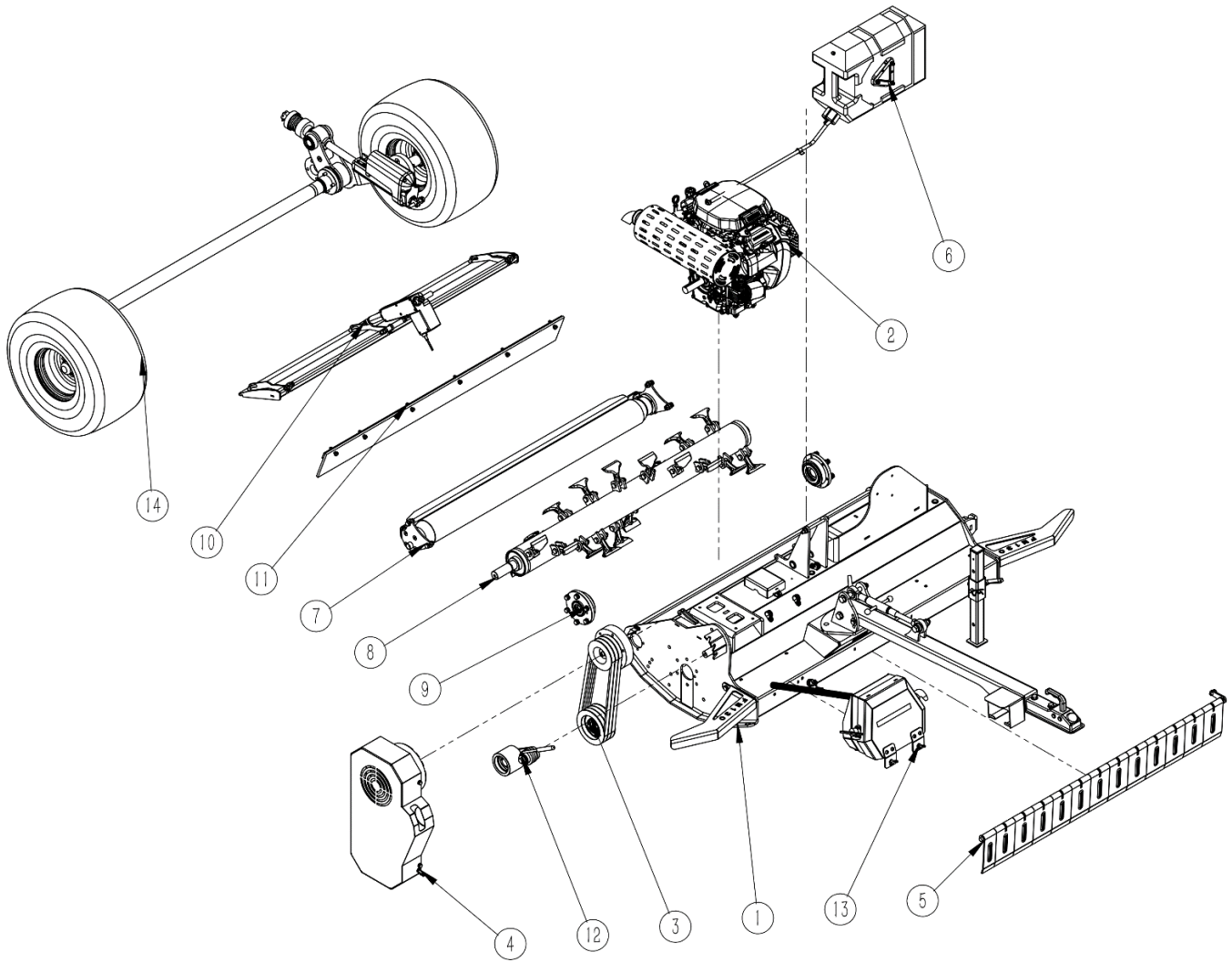

POS.	COD.	Specification	Description	Qty
1	2060107284	G11006C01000-000	Hood assembly	1
2	2060107122	G11006A14000-000	Engine mounting components	1
3	2060107285	G11006C07000-000	side drive assembly	1
4	2060107286	G11006C08000-000	Side protection cover assembly	1
5	2060107269	G11006B10000-000	protective components	1
6	2090005893	G11006A16000-000	Assembly	1
7	2060106705	G11003A03000-000	Roller assembly	1
8	2090006044	G11006A02000-000	knife shaft components	1
9	2060105468	G11001A04000-000	Cutter shaft bearing block assembly	1
10	2060107431	G11006C05000-000	Rear cover assembly	1
11	2060205310	G11006A17000-000	rubber baffle assembly	1
12	2060107271	G11006B20000-000	tighten the components	1
13	2060107272	G11006B15000-000	battery components	1
14	2060107611	G11006D13000-000	tire components	1

## HOOD ASSEMBLY

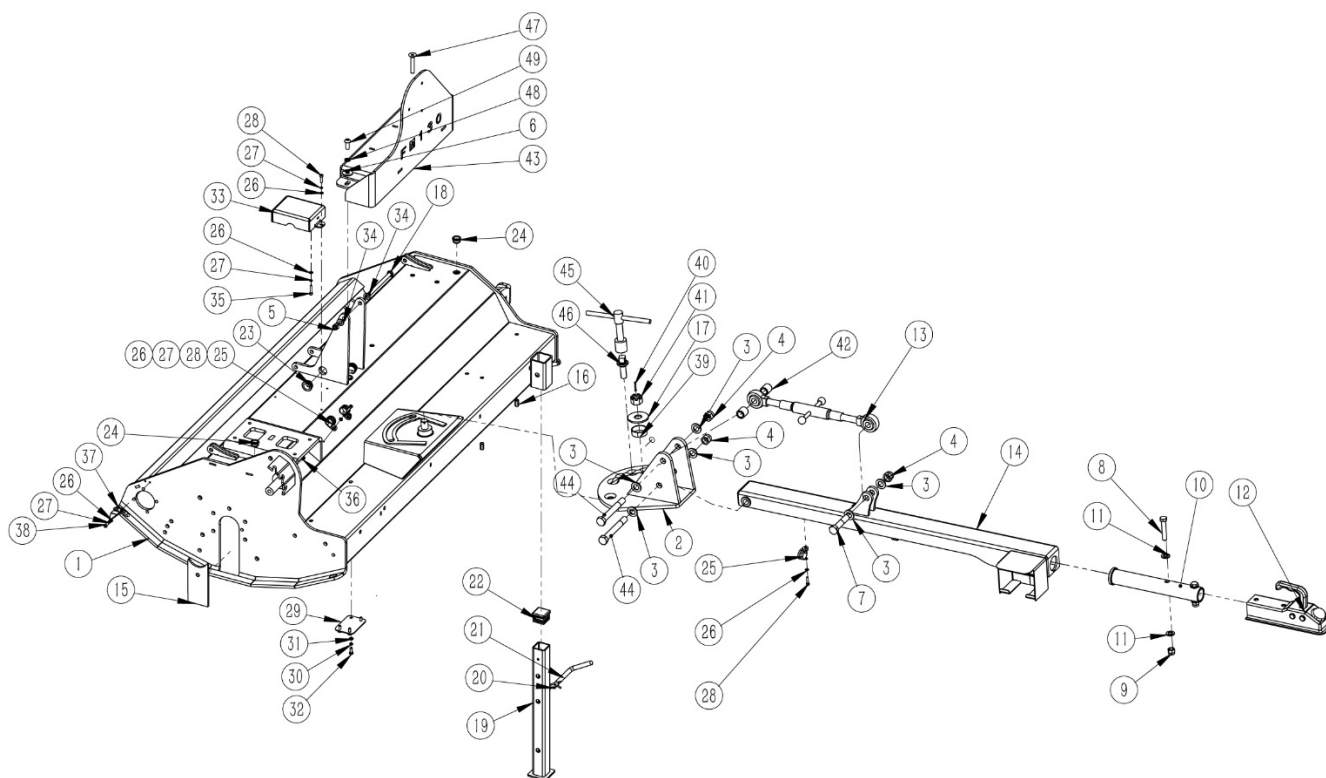

POS.	COD.	Specification	Description	Qty
1	2020007222	G11006C01100-000	Panel hood weldment	1
2	2020008792	G11006C01200-000	welding	1
3	3080100009	GB/T95-16-EP•Zn	Plain washer	6
4	3050500009	GB/T889.1-M16-8-EP•Zn	Locknut	3
5	3050500004	GB/T889.1-M10-8-EP•Zn	Locknut	1
6	3080200009	GB/T96.2-10-EP•Zn	Large plain washer	2
7	2010006606	G11006C01000-004	Hexagon head bolts	1
8	3040100076	GB/T5783-M12×65-8.8-EP•Zn	Full-thread hexagon bolts	2
9	3050500007	GB/T889.1-M12-8-EP•Zn	Locknut	2
10	2010000717	G11001A09000-002	Connecting pipe	1
11	3080100007	GB/T95-12-EP•Zn	Plain washer	4
12	3130500003	50×50"	Hitch ball coupler	1
13	3130500609	G11001A09000-004	Adjusting lever assembly	1
14	2020008801	G11006C01300-000	Tie rod welding	1

15	2000001001	G11001A01000-001	Side add plate	1
16	3051800002	M6×18-8-EP•Zn•P	Small countersunk full hexagon rivet nut	3
17	3080200013	GB/T96.2-20-EP•Zn	Large plain washer	1
18	3040300016	GB/T5782-M10×130-8.8-EP•Zn	Hexagon head bolts	1
19	2020006376	R02025A09200-000	Welded fittings for short supporting legs	1
20	3120400008	Din11024-4-EP•Zn	R Pin	1
21	2010005461	R02025A11000-010	Raker pin	1
22	3210200004	41×41	Square Pipe Plug	1
23	3210500700	XY-1031-BLACK	sheath coil	2
24	3210500699	XY-1025-BLACK	sheath coil	4
25	3130600020	Φ22	Lathe dog	6
26	3080100002	GB/T95-5-EP•Zn	Plain washer	12
27	3080500005	GB/T93-5-EP•Zn	Spring washer	12
28	3060100005	GB/T70.1-M5×20-8.8-EP•Zn	Hexagon socket head cap screws	8
29	2000005982	G11006A01000-003	plate	3
30	3080500006	GB/T93-6-EP•Zn	Spring washer	12
31	3080100003	GB/T95-6-EP•Zn	Plain washer	12
32	3040100005	GB/T5783-M6×16-8.8-EP•Zn	Full-thread hexagon bolts	12
33	2020007177	G11006A01400-000	welding	1
34	3080100006	GB/T95-10-EP•Zn	Plain washer	2
35	3060100006	GB/T70.1-M5×25-8.8-EP•Zn	Hexagon socket head cap screws	2
36	3170400002	JB/T7940.1-M6 304	Grease nipple	1
37	2000006282	G11006C01000-001	plate	1
38	3060300006	GB/T70.2-M6×16-8.8-EP•Zn	Hexagon socket button head screws	2
39	3100900627	SF-2-40×44×15	Bearing	1
40	3120100080	GB/T91-3.2×45	Split pin	1
41	3050800010	GB/T9459-M20×2-05-EP•Zn•P	Hexagon slotted and castle nuts	1
42	2010006387	G11006C01000-002	Spacer bush	2
43	2020008793	G11006C01500-000	Fuel tank bracket welded assembly	1
44	2010006605	G11006C01000-003	Hexagon head bolts	2
45	3140100638	G11006C01000-005	Handle	1

46	2020008791	G11006C01400-000	Compressed bolt welded assembly	1
47	3060200040	GB/T70.3-M10×60-8.8-EP•Zn	HSCS-Countersunk	2
48	3080500008	GB/T93-10-EP•Zn	Spring washer	2
49	3060300612	GB/T 70.2-2000	Hexagon socket button head screws	2

## SIDE DRIVE ASSEMBLY

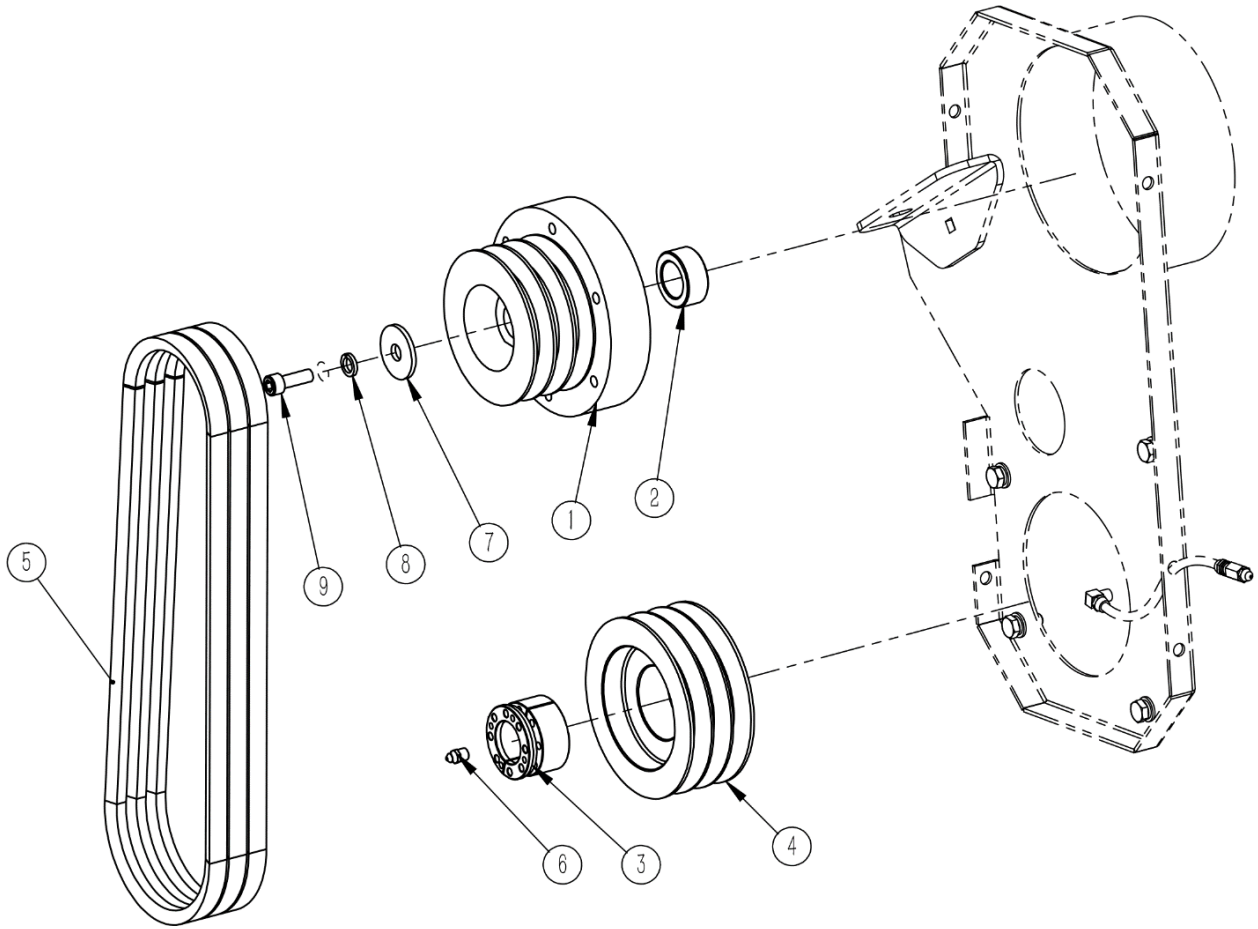

POS.	COD.	Specification	Description	Qty
1	3161000608	98-150-126-3B	Clutch	1
2	2000005906	G11006A07000-002	Clutch washer	1
3	3160500001	Z3A-35×60	Expanding sleeve	1
4	3160400062	SPB110-3-1-60-HT200-O	Pulley	1
5	3160300688	NAURENCE-SPB1106	Belt	3
6	3170400005	DIN71412-A G1/8 304	Grease nipple	1
7	3080300005	GB_T5287-12-EP_Zn	Extra Large plain washer	1
8	3080500009	GB/T93-12-EP•Zn	Spring washer	1
9	3041600013	7/16-20X30	HSCS-Cap 7/16-20X30	1

## BELT GUARD ASSEMBLY

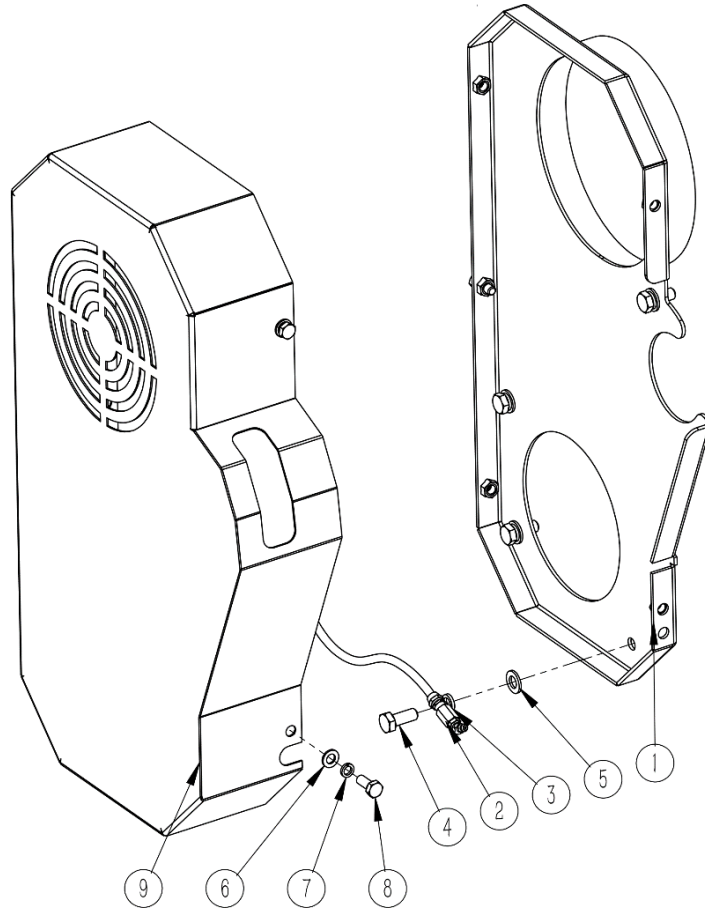

POS.	COD.	Specification	Description	Qty
1	2020007223	G11006C08300-000	Belt guard base plate weldment	1
2	2090006043	G11006A08100-000	Grease assembly	1
3	3080500008	GB/T93-10-EP•Zn	Spring washer	4
4	3040100043	GB/T5783-M10×25-8.8-EP•Zn	Full-thread hexagon bolts	4
5	3080100006	GB/T95-10-EP•Zn	Plain washer	4
6	3080100004	GB/T95-8-EP•Zn	Plain washer	4
7	3080500007	GB/T93-8-EP•Zn	Spring washer	4
8	3040100022	GB/T5783-M8×20-8.8-EP•Zn	Full-thread hexagon bolts	4
9	2020007203	G11006B08200-000	Cover plate weldment	1

## BAFFLE ASSEMBLY

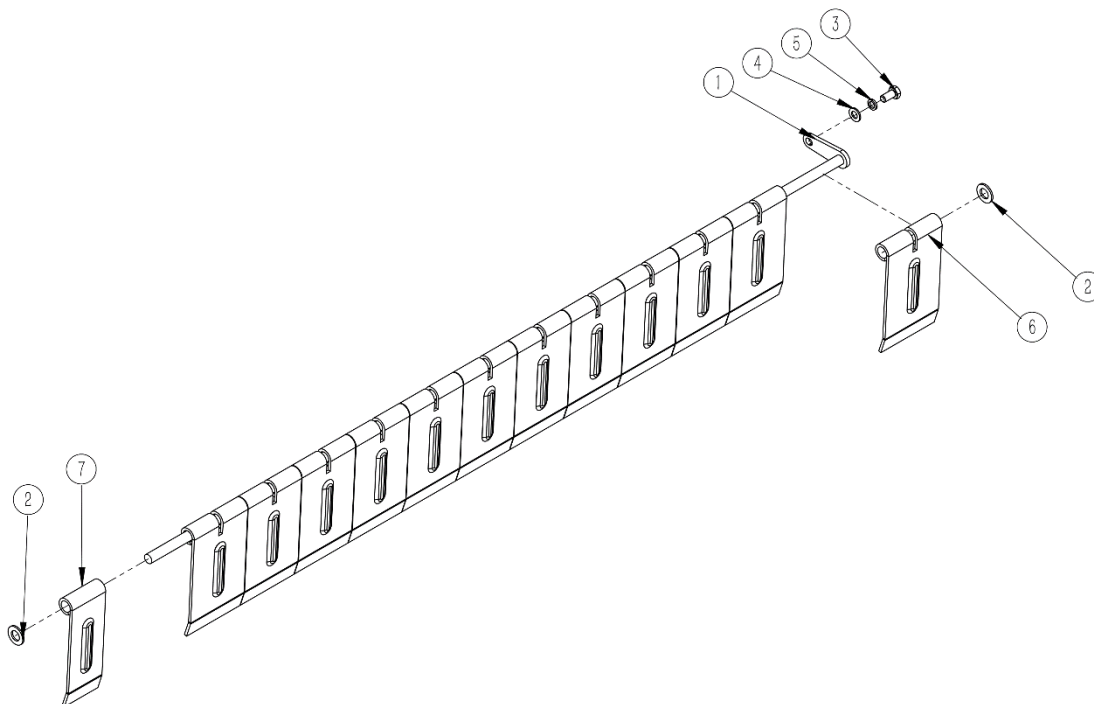

POS.	COD.	Specification	Description	Qty
1	2020007022	G11006A10100-000	axle welding	1
2	3080100008	GB/T95-14-EP•Zn	Plain washer	2
3	3040100041	GB/T5783-M10×20-8.8-EP•Zn	Full-thread hexagon bolts	1
4	3080100006	GB/T95-10-EP•Zn	Plain washer	1
5	3080500008	GB/T93-10-EP•Zn	Spring washer	1
6	2000006100	G11006B10000-001	Baffle Plate	12
7	2000006101	G11006B10000-002	Baffle Plate	1

# WHEEL ASSEMBLY

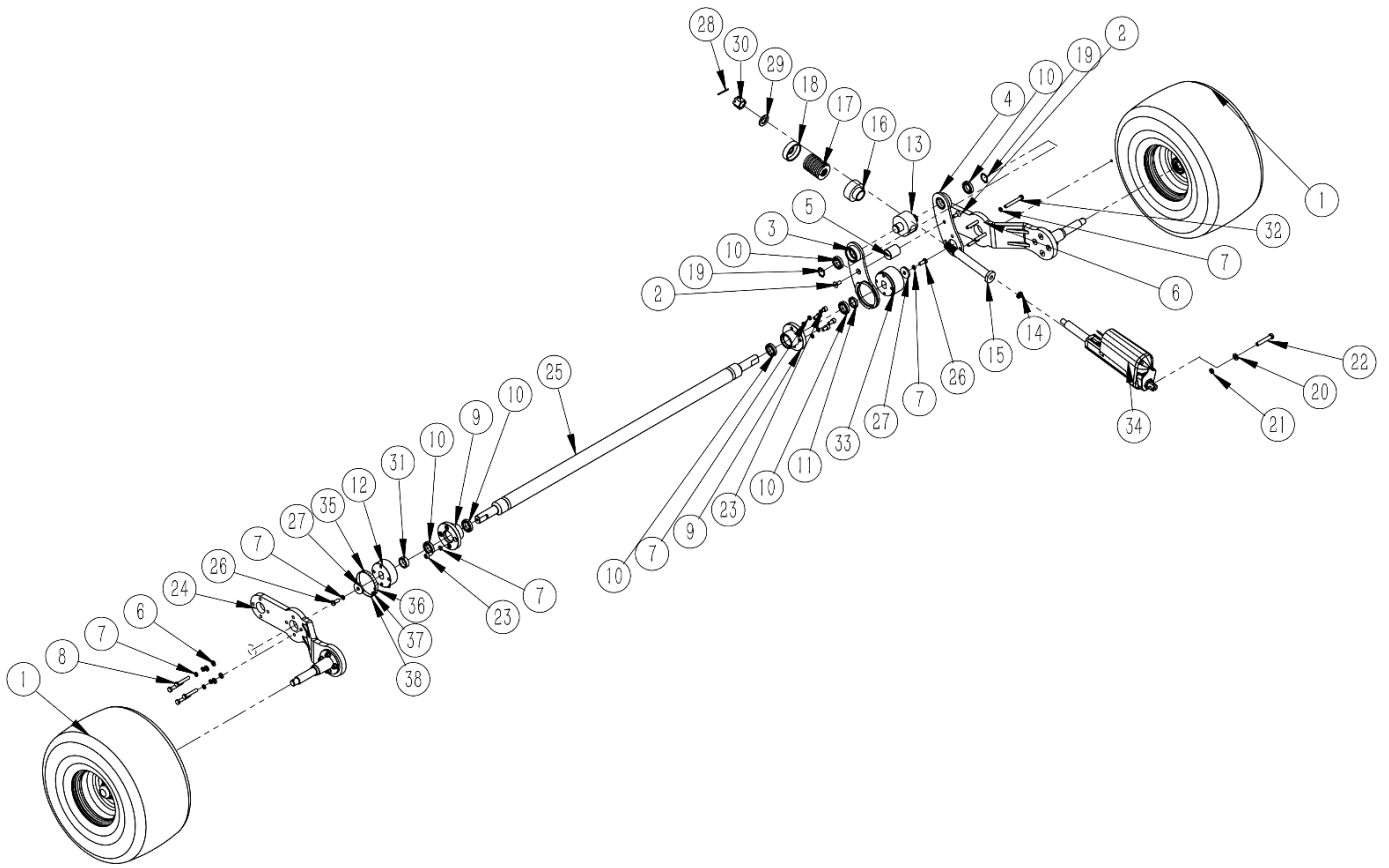

POS.	COD.	Specification	Description	Qty
1	2090006048	G11001B13100-000	Tire components	2
2	3060200033	GB/T70.3-M10×25-8.8-EP•Zn	HSCS-Countersunk	2
3	2020007023	G11006A13400-000	adjustment plate welding	1
4	2020007209	G11006B13500-000	plate welding	1
5	2010000726	G11001A13000-008	Adjustment plate	1
6	3080100006	GB/T95-10-EP•Zn	Plain washer	8
7	3080500008	GB/T93-10-EP•Zn	Spring washer	18
8	3040100051	GB/T5783-M10×60-8.8-EP•Zn	Full-thread hexagon bolts	4
9	2010005641	G11006A13000-011	axis	2
10	3100100063	UBC-61906-2Z	Deep groove ball bearing	6
11	2010005634	G11006A13000-002	ring	1
12	2010005890	G11006D13000-001	Tire adjustment sleeve	1
13	2010005642	G11006A13000-012	axis	1
14	3080500011	GB/T93-16-EP•Zn	Spring washer	1
15	2010005853	G11006C13000-014	screw	1
16	2010005640	G11006A13000-010	ring	1
17	3119900032	GREEN60x80	spring	1
18	2010005724	G11006B13000-009	spring seating	1
19	3080700020	GB/T894-30-A	Retaining rings for shaft	2
20	3080100007	GB/T95-12-EP•Zn	Plain washer	1
21	3080500009	GB/T93-12-EP•Zn	Spring washer	1
22	3040300023	GB/T5782-M12×70-10.9-EP•Zn	Hexagon head bolts	1
23	3060100038	GB/T70.1-M10×20-8.8-EP•Zn	Hexagon socket head cap screws	8
24	2060205442	G11006B13200-000	Regulator plate components	2
25	2020007559	G11006C13100-000	Tube welding	1
26	3040100043	GB/T5783-M10×25-8.8-EP•Zn	Full-thread hexagon bolts	2
27	2000001008	G11001A13000-009	Adjust the shaft pressure plate	2
28	3120100080	GB/T91-3.2×45	Split pin	1
29	3080100013	GB/T95-24-EP•Zn	Plain washer	1

30	3050800012	GB/T9459-M24×2-05-EP•Zn•P	Hexagon slotted and castle nuts	1
31	2010005822	G11006B13000-005	ring	1
32	3040100055	GB/T5783-M10×80-8.8-EP•Zn	Full-thread hexagon bolts	4
33	2010005889	G11006D13000-002	Tire adjustment sleeve	1
34	3190500606	Actuator LA36	Actuator LA36	1
35	3250101198	G11006C13000-003	Adhesive stainless steel ruler stick	1
36	3080100002	GB/T95-5-EP•Zn	Plain washer	2
37	3080500005	GB/T93-5-EP•Zn	Spring washer	2
38	3060300605	GB/T 70.2-2000	Hexagon socket button head screws	2

## REGULATOR PLATE COMPONENTS

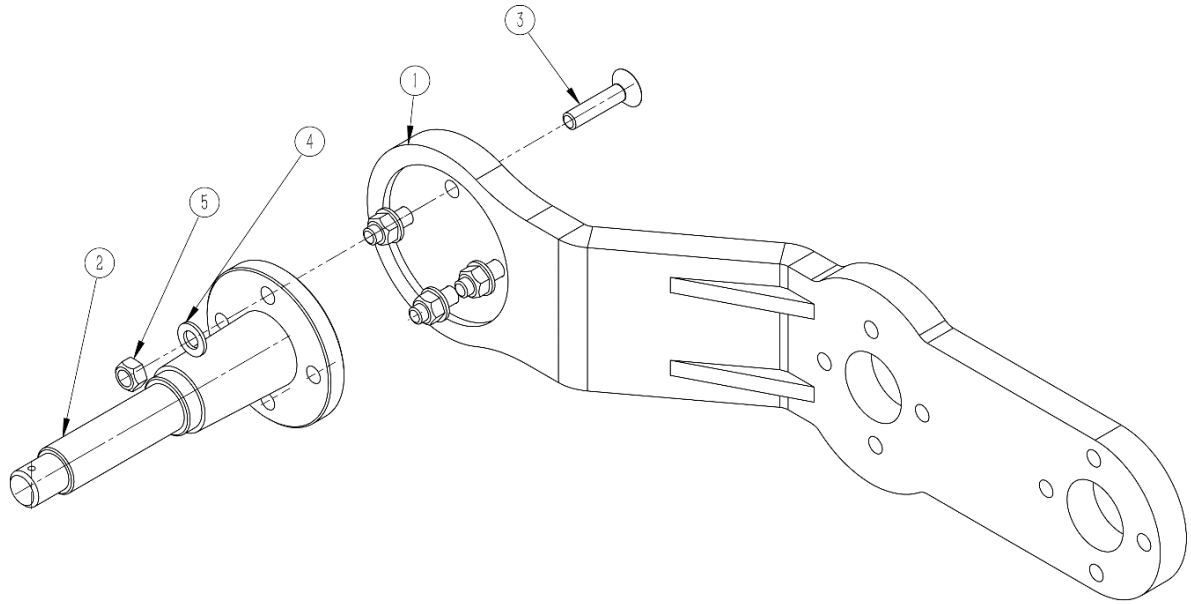

POS.	COD.	Specification	Description	Qty
1	2020007604	G11006B13210-000	Adjusting plate welding	1
2	2010005722	G11006A13200-002	tire shaft	1
3	3060200613	GB/T70.3-M10×45-12.9-EP•Zn	Bolt	4
4	3080100006	GB/T95-10-EP•Zn	Plain washer	4
5	3051500600	GB/T6184-M10-8-EP•Zn	Metal locknut	4

## TIRE ASSEMBLY

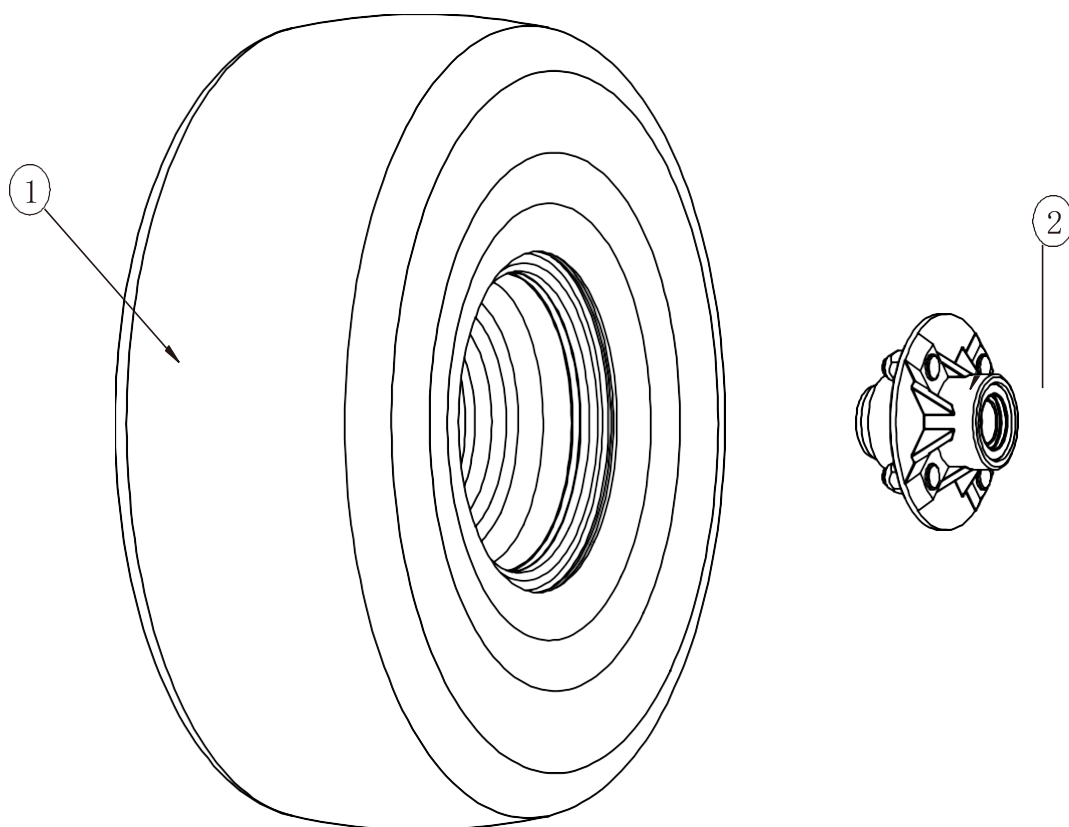

POS.	COD.	Specification	Description	Qty
1	3140200025	P323 TIRE 22×11-8+ WHITE RIM 8×8 4-101.6	Tire components	1
2	3140200625	HUB 4-101.6-1	The bearing shell	1

## ENGINE MOUNTING ASSEMBLY

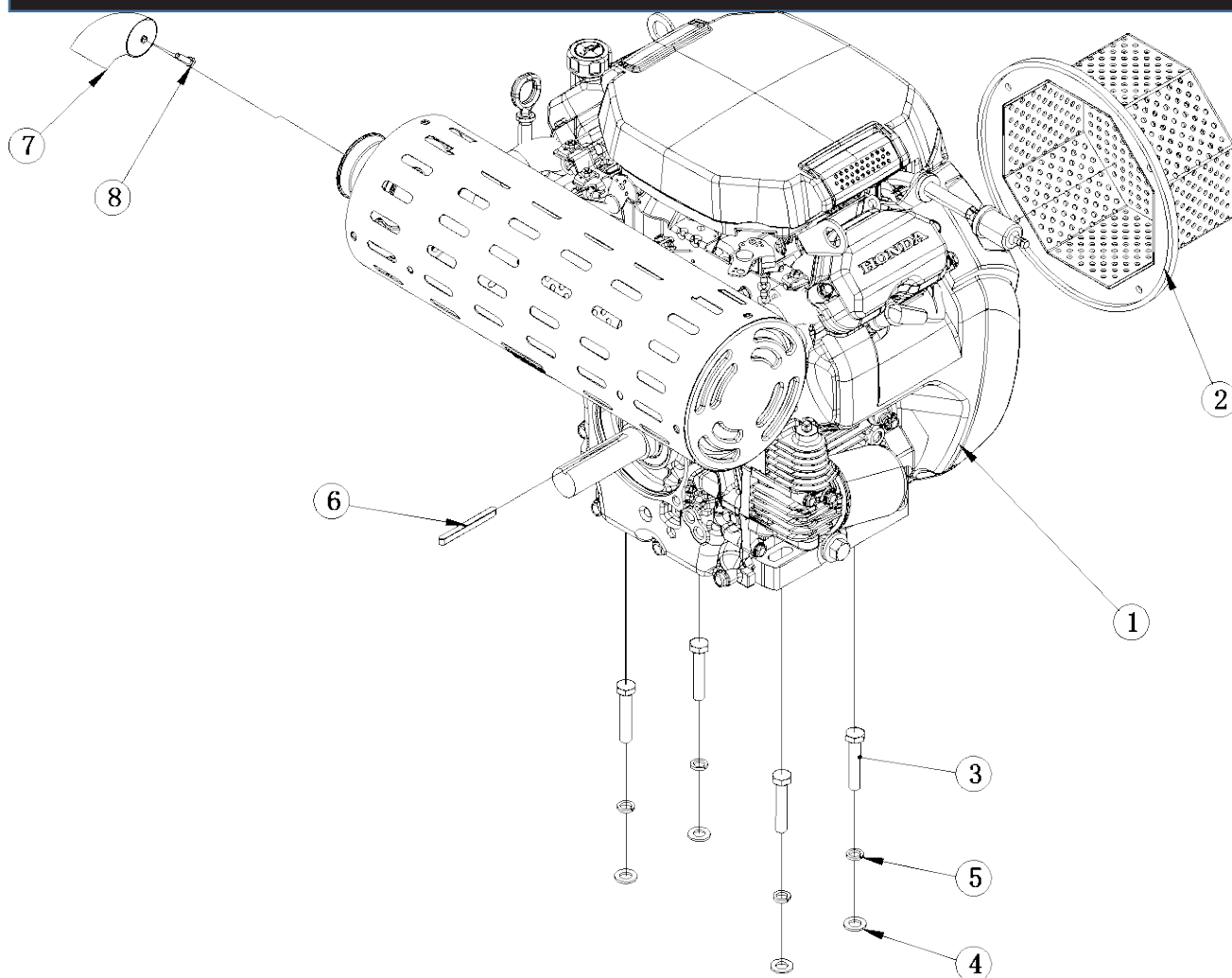

POS.	COD.	Specification	Description	Qty
1	3200100614	HONDA GX690	Engine	1
2	2020006953	G11006A14100-000	Air inlet weldment	1
3	3040100050	GB/T5783-M10X55-8.8-EP·Zn	Full-thread hexagon bolts	4
4	3080100006	GB/T95-10-EP·Zn	Plain washer	4
5	3080500008	GB/T93-10-EP·Zn	Spring washer	4
6	3090400603	6.3*6.3*70	Parallel key	1
7	2020002005	G11001A14100-000	Exhaust pipe weldment	1
8	3040100002	GB/T5783-M5X20-8.8-EP·Zn	Full-thread hexagon bolts	1

## BLADE ASSEMBLY (OPTIONAL)

**Spiral rotor + hammer flail**

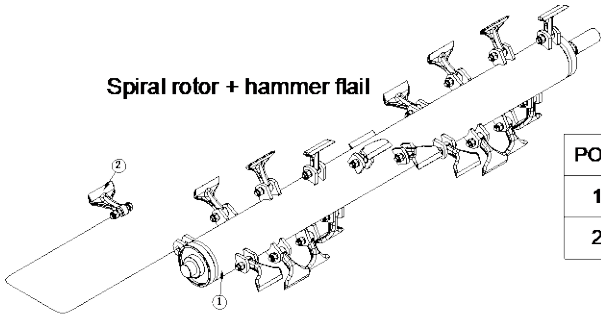

POS.	COD.	Specification	Description	Qty
1	2020007204	G11006A02100-000	Rotor weldment	1
2	2060205384	G11006A02200-000	Hammer flail assembly	20

**Common rotor + hammer flail**

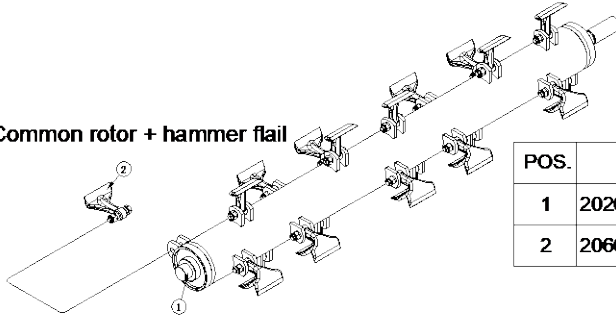

POS.	COD.	Specification	Description	Qty
1	2020007205	G11006B02100-000	Rotor weldment	1
2	2060205384	G11006A02200-000	Hammer flail assembly	20

**Spiral rotor + Y flail**

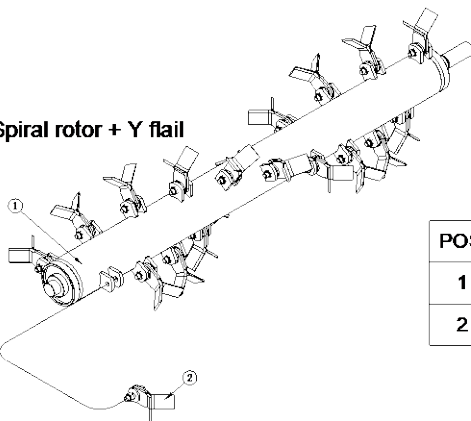

POS.	COD.	Specification	Description	Qty
1	2020007204	G11006A02100-000	Rotor weldment	1
2	2060204855	G01009B02200-000	Y flail assembly	20

**Common rotor + Y flail**

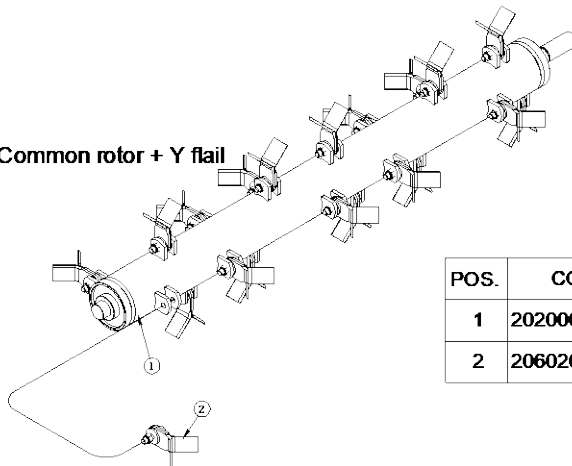

POS.	COD.	Specification	Description	Qty
1	2020007205	G11006B02100-000	Rotor weldment	1
2	2060204855	G01009B02200-000	Y flail assembly	20

## BLADE ASSEMBLY (OPTIONAL)

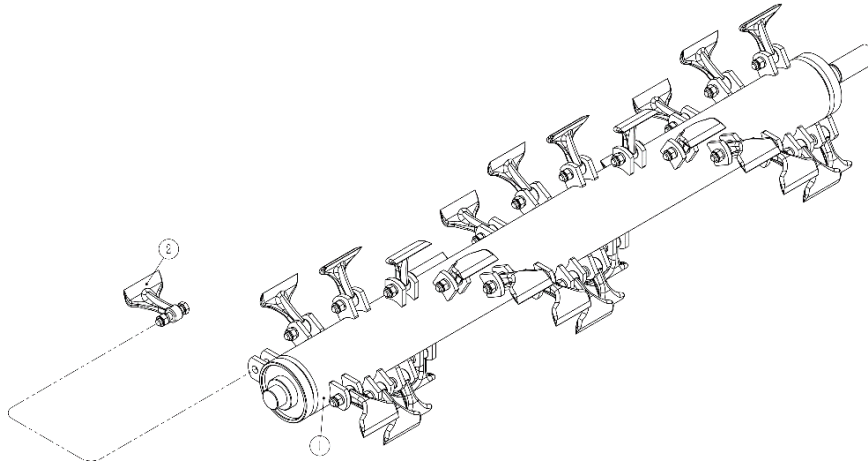

POS.	COD.	Specification	Description	Qty
1	2020007216	G11006C02100-000	welding	1
2	2060205384	G11006A02200-000	Blade components	30

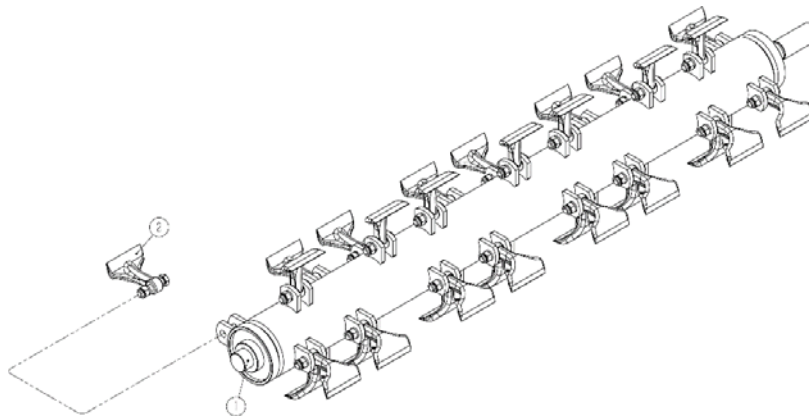

POS.	COD.	Specification	Description	Qty
1	2020007220	G11006D02100-000	welding	1
2	2060205384	G11006A02200-000	Blade components	30

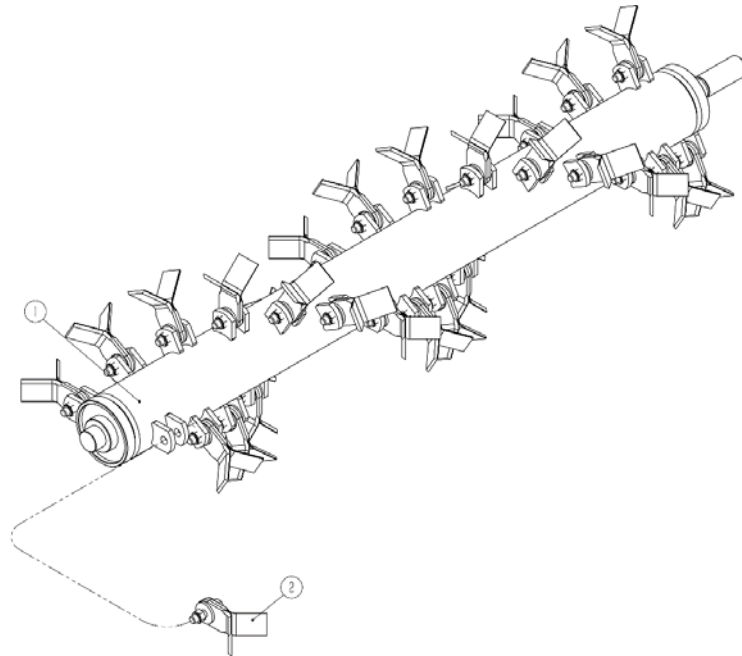

POS.	COD.	Specification	Description	Qty
1	2020007216	G11006C02100-000	welding	1
2	2060204855	G01009B02200-000	Blade assembly	30

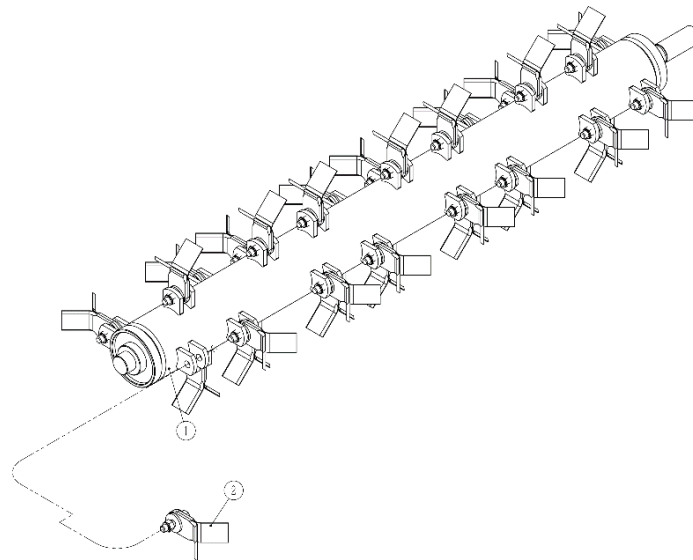

POS.	COD.	Specification	Description	Qty
1	2020007220	G11006D02100-000	welding	1
2	2060204855	G01009B02200-000	Blade assembly	30

## BATTERY ASSEMBLY

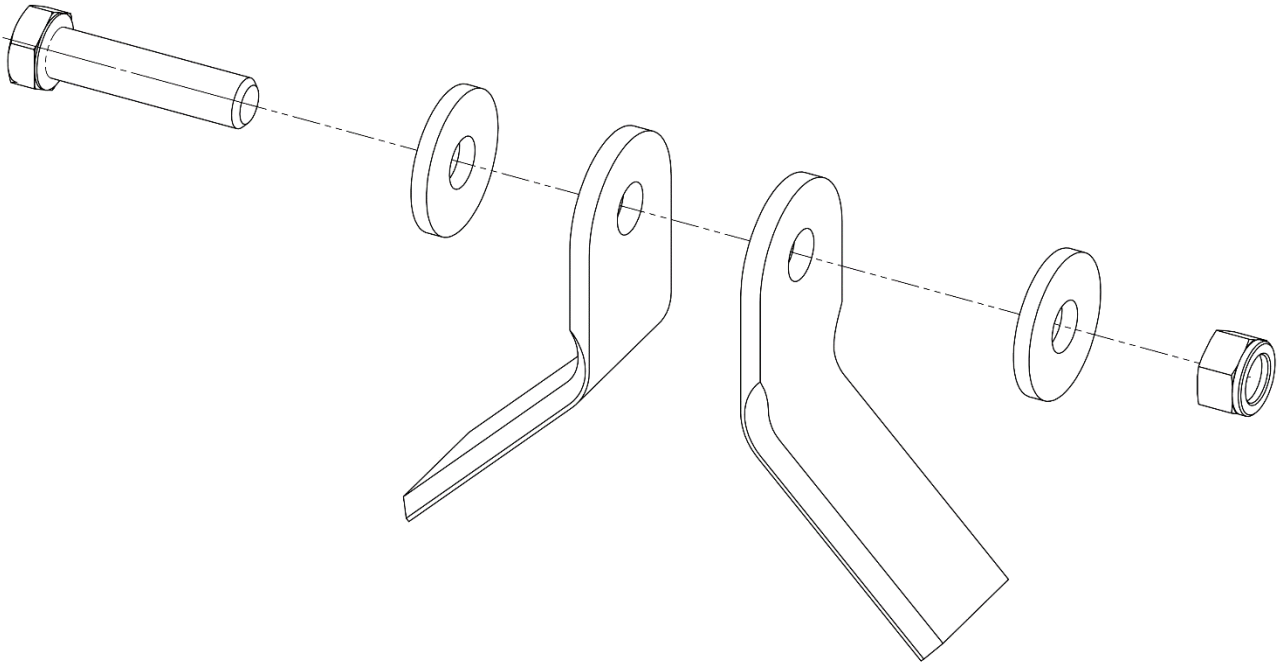

POS.	COD.	Specification	Description	Qty
1	3040300608	GB/T5782-M12×50-10.9-O	Hexagon head bolts	1
2	3050500007	GB/T889.1-M12-8-EP•Zn	Locknut	1
3	3220100027	MT02011	Blade	2
4	2000000001	G01009B02200-001	Blade spacer	2

## BATTERY ASSEMBLY

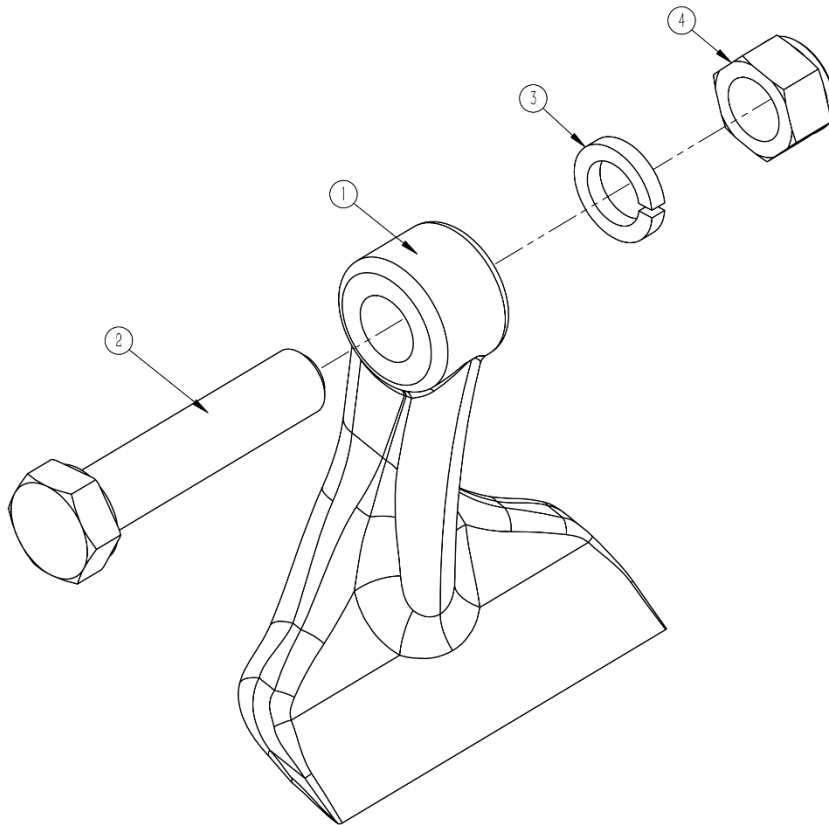

POS.	COD.	Specification	Description	Qty
1	3220100034	MT01020	Blade	1
2	3040300020	GB/T5782-M12×55-10.9-O	Hexagon head bolts	1
3	3080500009	GB/T93-12-EP•Zn	Spring washer	1
4	3050500007	GB/T889.1-M12-8-EP•Zn	Locknut	1

# FUEL TANK ASSEMBLY

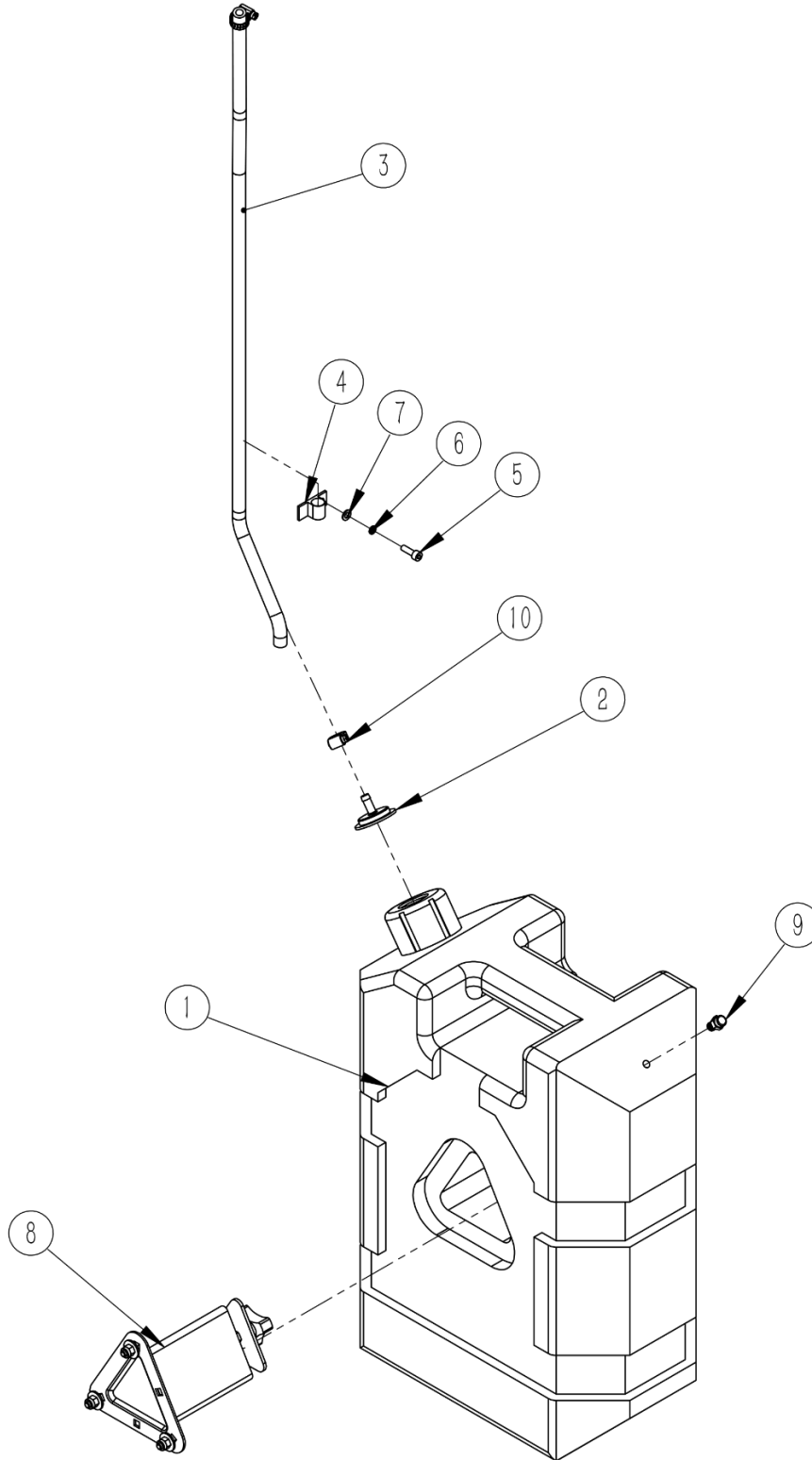

POS.	COD.	Specification	Description	Qty
1	3200200677	21L(BLACK)	Accessories	1
2	2010000733	G11001A16000-001	Fuel tank connector	1
3	3200100627	Φ6×1000	Engine	1
4	3210100603	8J-S-12	Lock	1
5	3060100004	GB/T70.1-M5×16-8.8-EP•Zn	Hexagon socket head cap screws	1
6	3080500005	GB/T93-5-EP•Zn	Spring washer	1
7	3080100002	GB/T95-5-EP•Zn	Plain washer	1
8	3200200679	G11006A16000-001	tank hanger	1
9	3200200692	M8X1.25-L10-304	Accessories	1
10	3140600004	QJ177.16A-16-6-ES	Hose clamp	2

## ROLLER ASSEMBLY

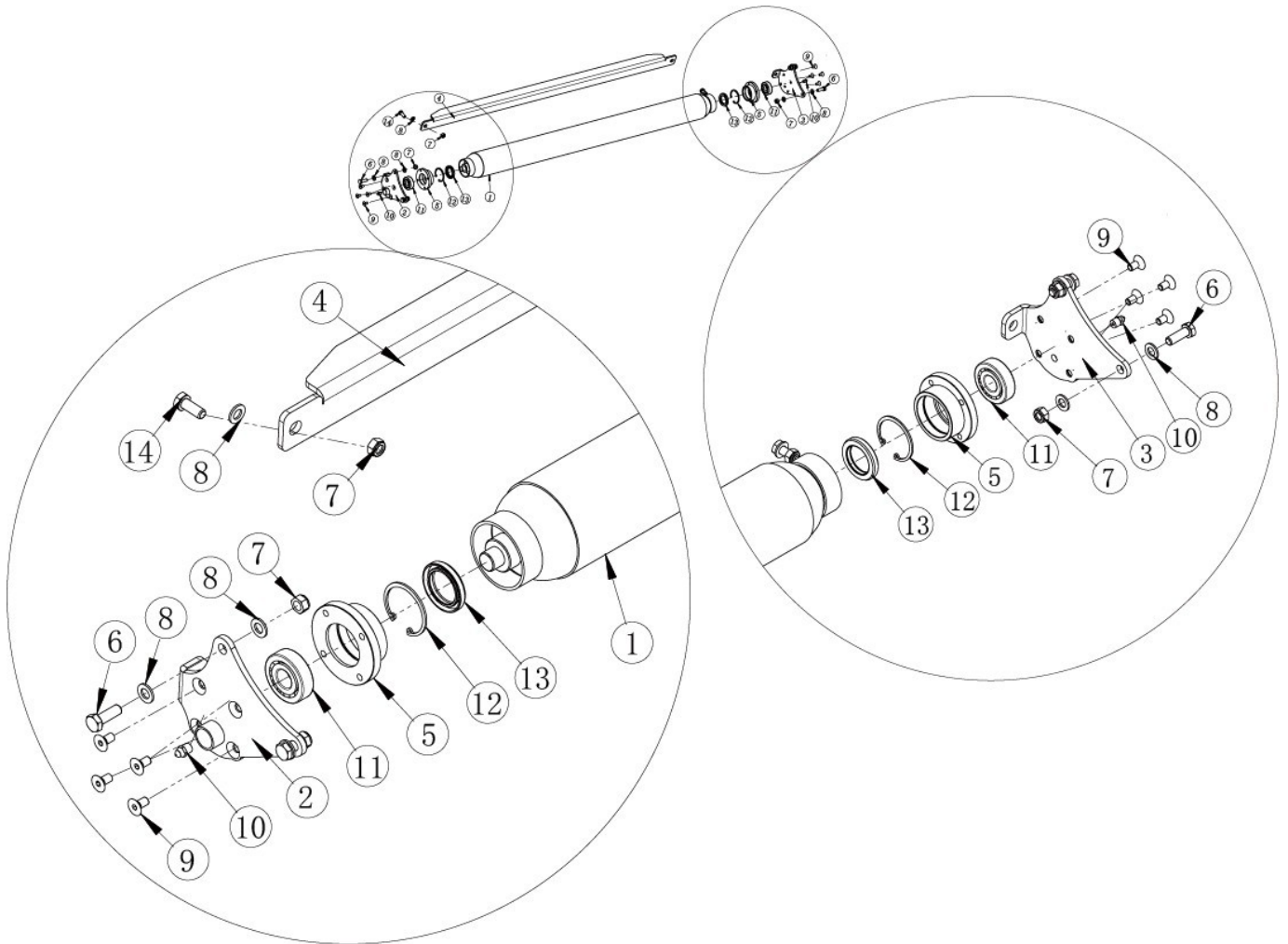

POS.	COD.	Specification	Description	Qty
1	2020006177	G11003A03100-000	Roller weldment	1
2	2020007171	G11003A03200-000	Adjustment plate weldment	1
3	2020007172	G11003A03300-000	Adjustment plate weldment	1
4	2000005475	G11003A03000-001	Scraper	1
5	3240300005	G01009A03000-001	Bearing Block	2
6	3040100045	GB/T5783-M10×30-8.8-EP•Zn	Full-thread hexagon bolts	4
7	3050500004	GB/T889_1-M10-8-EP•Zn	Locknut	6
8	3080100006	GB/T95-10-EP•Zn	Plain washer	10
9	3060200017	GB/T70.3-M8×16-8.8-EP•Zn	HSCS-Countersunk screw	8
10	3170400005	DIN71412-A G1/8 304	Grease nipple	2
11	3100200006	GB/T281-1304	Self-aligning ball bearing	2
12	3080600033	GB/T893-52-A	Retaining ring	2
13	3170100007	GB/T13871.1-FB-35×52×8-NBR	Shaft seal	2
14	3040100043	GB/T5783-M10×25-8.8-EP•Zn	Full-thread hexagon bolts	2

## LONG SHAFT BEARING SEAT ASSEMBLY

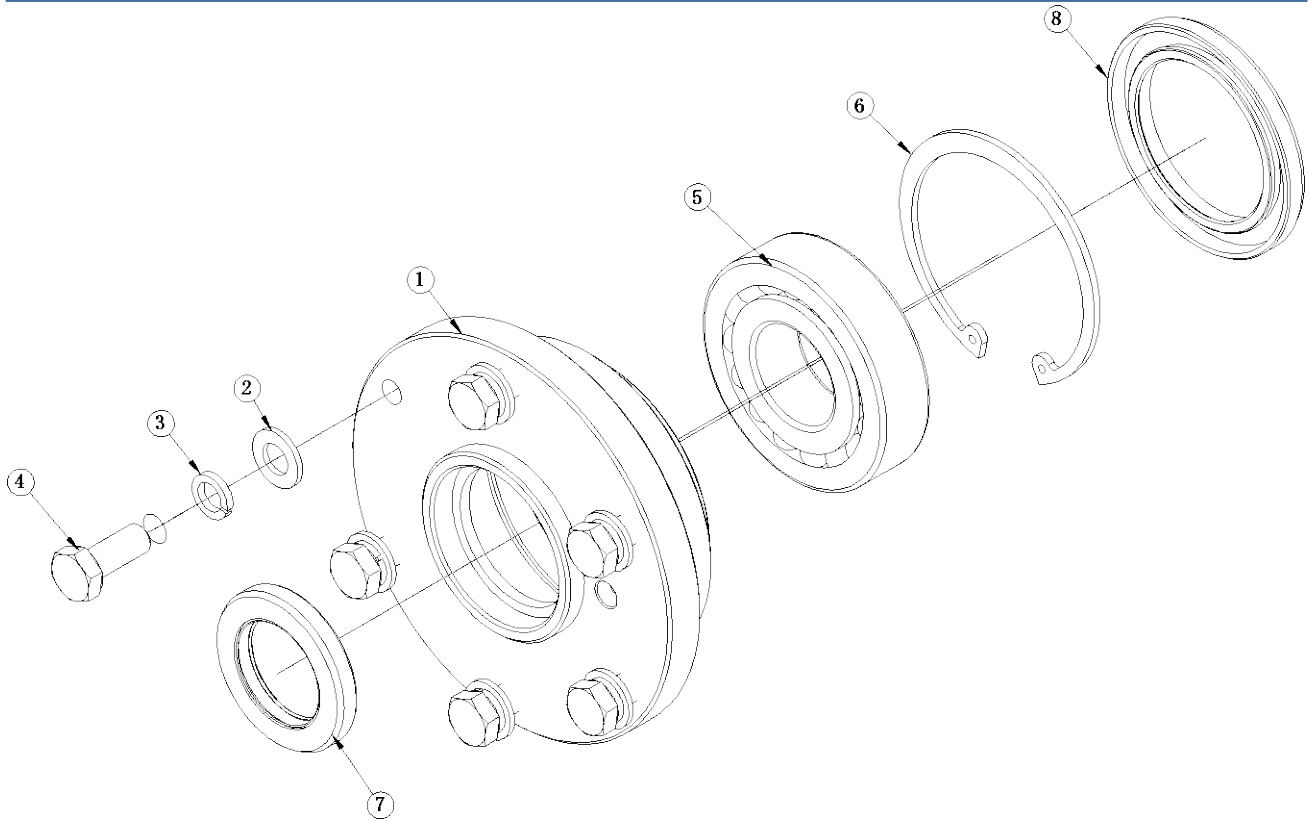

POS.	COD.	Specification	Description	Qty
1	3150100061	G11001A04100-001	Long shaft head bearing seat	1
2	3080100006	GB/T95-10-EP•Zn	Plain washer	6
3	3080500008	GB/T93-10-EP•Zn	Spring washer	6
4	3040100043	GB/T5783-M10×25-8.8-EP•Zn	Full-thread hexagon bolts	6
5	3100200008	GB/T281-1307	Self-aligning ball bearing	1
6	3080600046	GB/T893-80-A	Retaining rings	1
7	3170100008	GB/T13871.1-FB-35×55×8-NBR	Shaft seal	1
8	3170100046	GB/T13871.1-FB-55×80×8-NBR	Shaft seal	1

## SHORT SHAFT BEARING SEAT ASSEMBLY

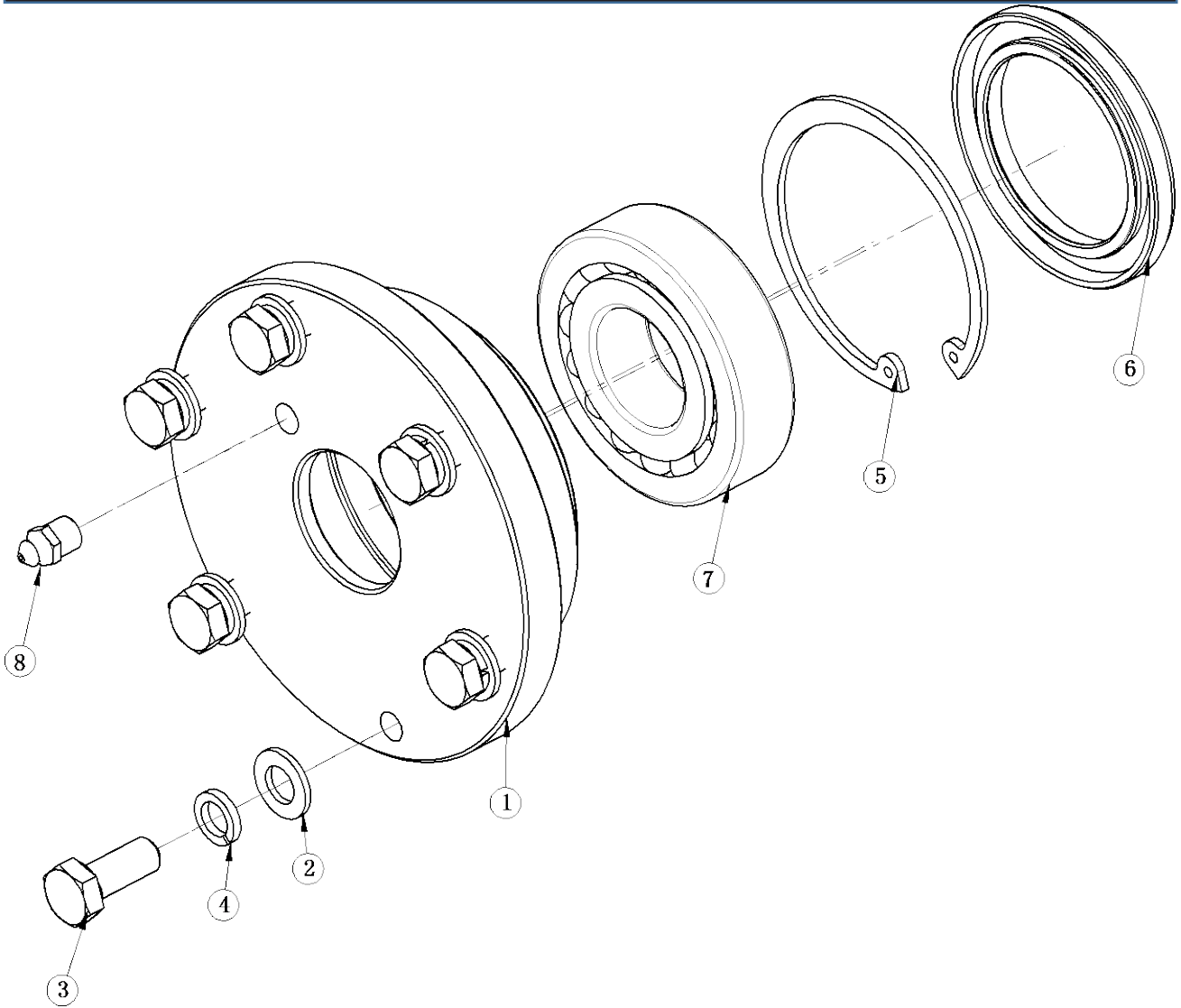

POS.	COD.	Specification	Description	Qty
1	3150100004	F01001A05000-001	Bearing seat	1
2	3080100006	GB/T95-10-EP•Zn	Plain washer	6
3	3040100043	GB/T5783-M10×25-8.8-EP•Zn	Full-thread hexagon bolts	6
4	3080500008	GB/T93-10-EP•Zn	Spring washer	6
5	3080600046	GB/T893-80-A	Retaining rings	1
6	3170100046	GB/T13871.1-FB-55×80×8-NBR	Shaft seal	1
7	3100200008	GB/T281-1307	Self-aligning ball bearing	1
8	3170400005	DIN71412-A G1/8 304	Grease nipple	1

## REAR COVER ASSEMBLY

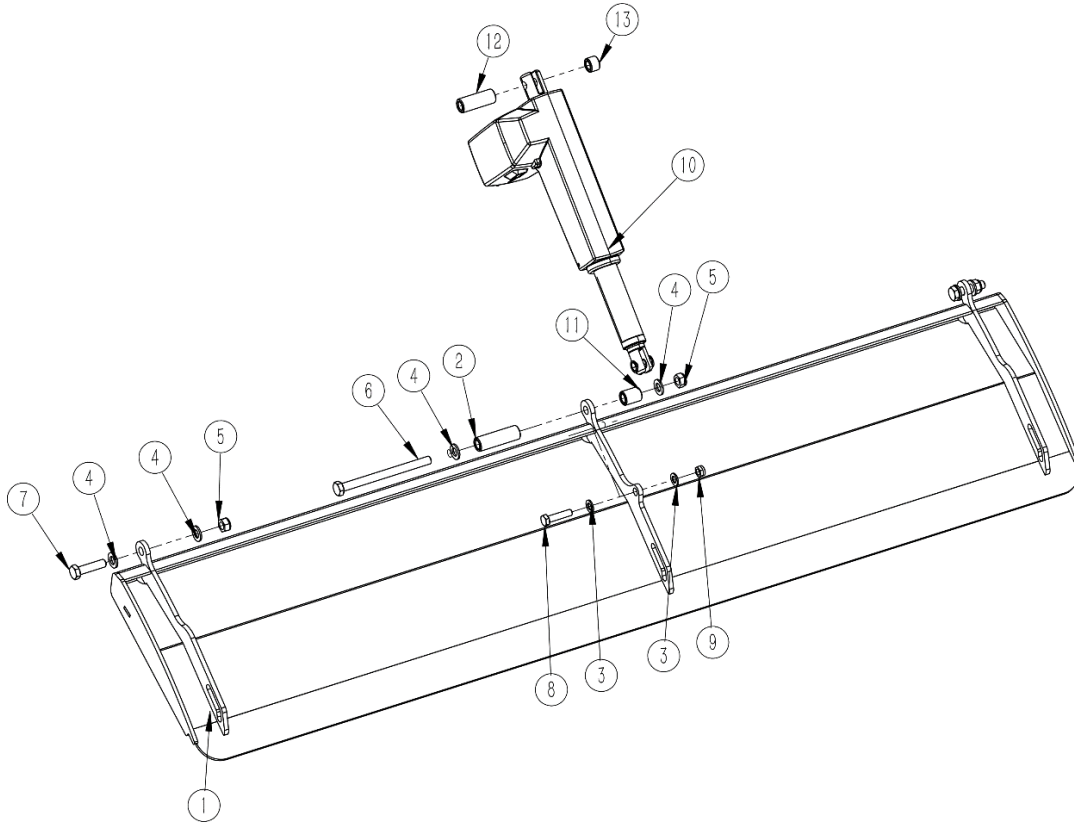

POS.	COD.	Specification	Description	Qty
1	2020007206	G11006B05100-000	Cover plate welded parts	1
2	2010005837	G11006C05000-002	Spacer	1
3	3080100004	GB/T95-8-EP•Zn	Plain washer	2
4	3080100006	GB/T95-10-EP•Zn	Plain washer	6
5	3050500004	GB/T889.1-M10-8-EP•Zn	Locknut	3
6	3040100061	GB/T5783-M10×130-8.8-EP•Zn	Full-thread hexagon bolts	1
7	3040100047	GB/T5783-M10×40-8.8-EP•Zn	Full-thread hexagon bolts	2
8	3040100026	GB/T5783-M8×35-8.8-EP•Zn	Full-thread hexagon bolts	1
9	3050500003	GB/T889.1-M8-8-EP•Zn	Locknut	1
10	3190500607	Actuator LA31	Actuator LA31	1
11	2010005838	G11006C05000-001	Spacer	1
12	2010005854	G11006C05000-003	Spacer	1
13	2010005855	G11006C05000-004	Spacer	1

## RUBBER BAFFLE ASSEMBLY

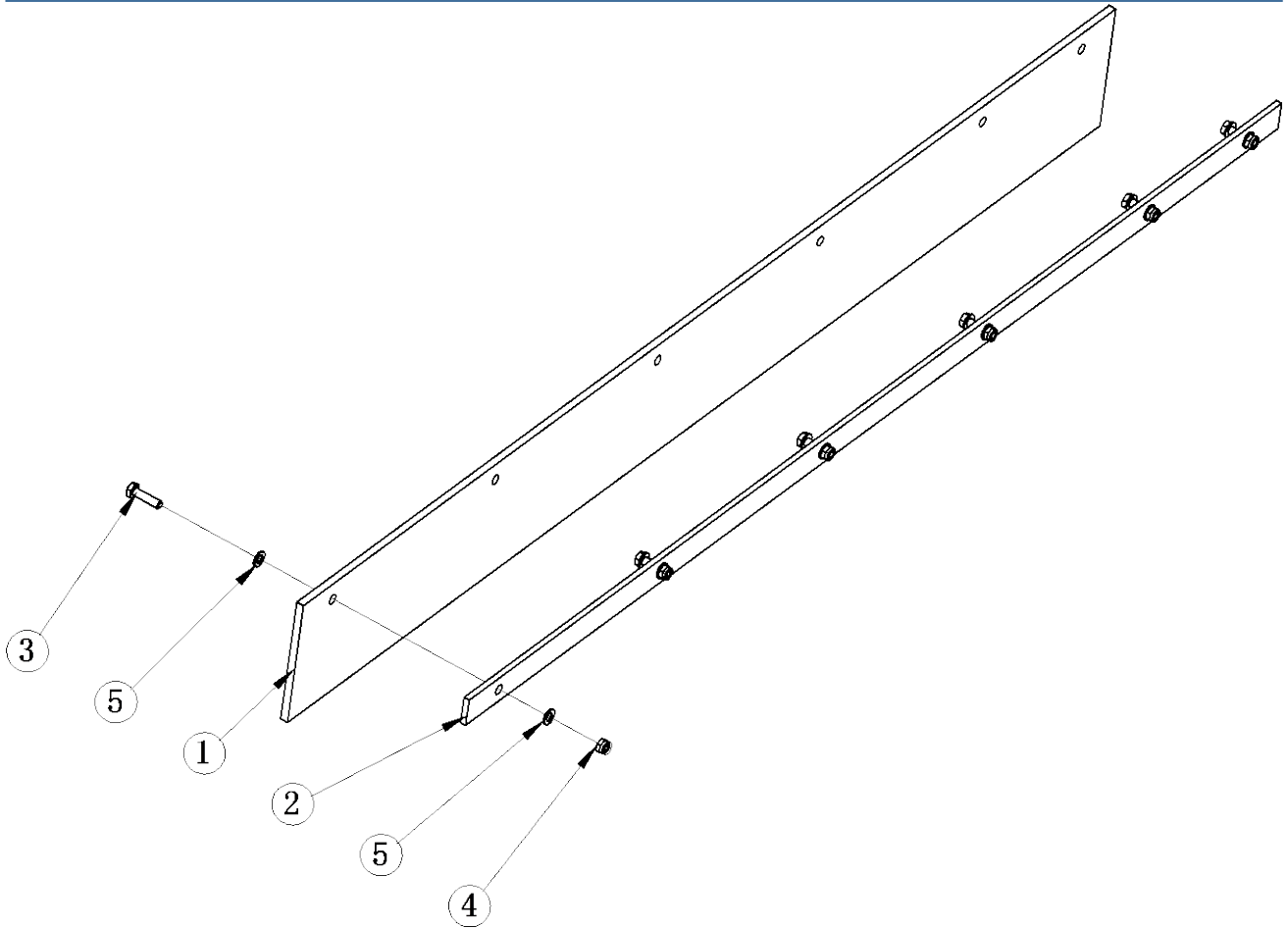

POS.	COD.	Specification	Description	Qty
1	3210500693	G11006A17000-001	Rubber curtain	1
2	2000005933	G11006A17000-002	Mounting bar	1
3	3040100025	GB/T5783-M8X30-8.8-EP·Zn	Full-thread hexagon bolts	6
4	3050500003	GB/T889.1-M8-8-EP·Zn	Locknut	6
5	3080100004	GB/T95-8-EP·Zn	Plain washer	12

## BELT TENSIONING ASSEMBLY

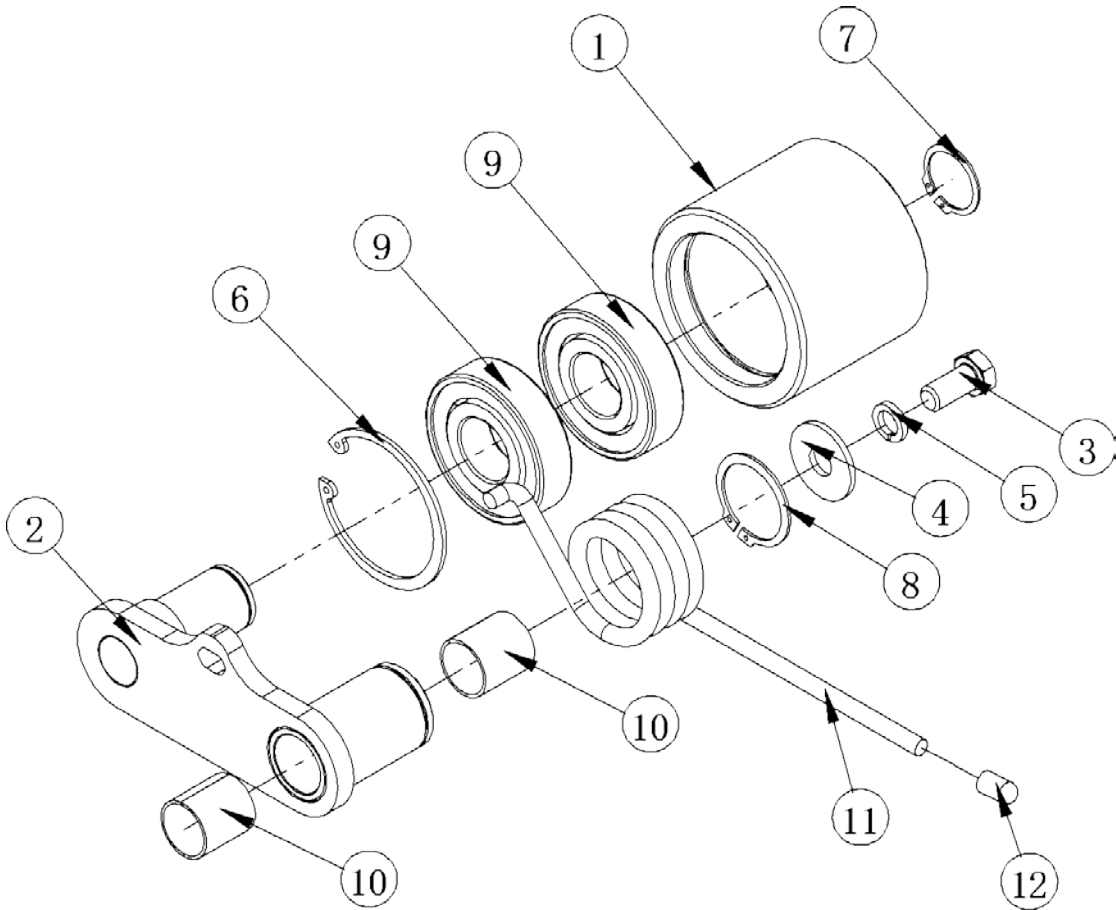

POS.	COD.	Specification	Description	Qty
1	2010005720	G11006B20000-001	Tension pulley	1
2	2020006368	F02022A10100-000	Tension pulley weldment	1
3	3040100065	GB/T5783-M12×25-8.8-EP•Zn	Full-thread hexagon bolts	1
4	3080200010	GB/T96.2-12-EP•Zn	Large plain washer	1
5	3080500009	GB/T93-12-EP•Zn	Spring washer	1
6	3080600043	GB/T893-72-A	Retaining ring	1
7	3080700020	GB/T894-30-A	Retaining ring	1
8	3080700026	GB/T894-40-A	Retaining ring	1
9	3100100631	GB/T 276-94	Deep groove ball bearing	2
10	3100900612	SF-2-25×28×30	Bushings	2
11	3110100617	LII-8×54×215×4-L-65Mn-EP•Zn	Tension spring	1
12	3210500710	Φ8×100 (black)	Φ8×100 (black)	1

# BATTERY ASSEMBLY

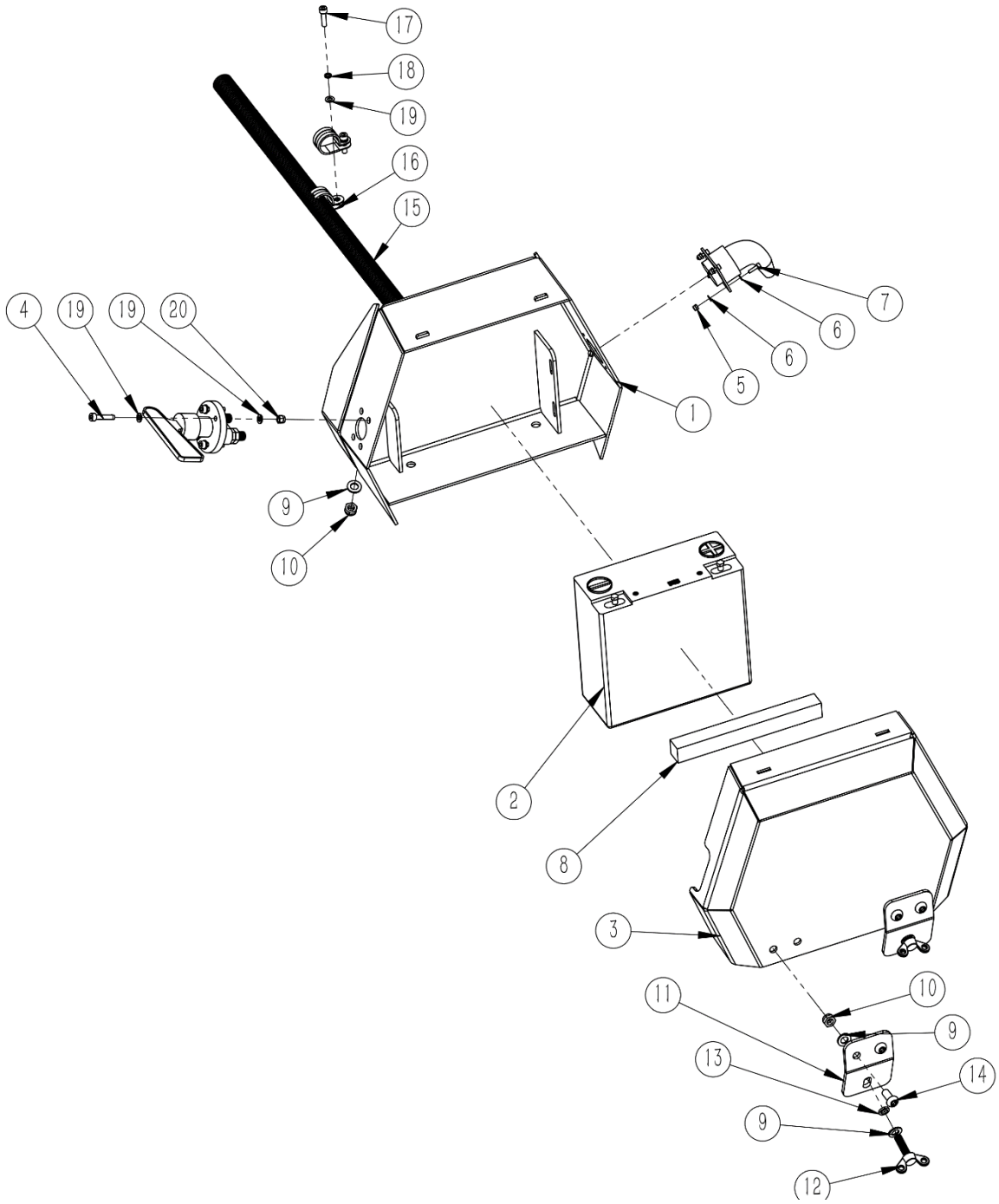

POS.	COD.	Specification	Description	Qty
1	2020007207	G11006B15100-000	Battery box welding fittings	1
2	3190400001	12V-20AH(180*75*168)	Battery	1
3	2000006102	G11006B15000-001	battery cover	1
4	3060100006	GB/T70.1-M5×25-8.8-EP•Zn	Hexagon socket head cap screws	4
5	3050500005	GB/T889.1-M3-8-EP•Zn	Locknut	4
6	3080100621	GB/T95-4-EP•Zn	Plain washer	8
7	3060100635	GB/T70.1-M3×12-8.8-EP•Zn	bolt	4
8	3210500707	G11006B15000-003	rubber	1
9	3080100004	GB/T95-8-EP•Zn	Plain washer	8
10	3050500003	GB/T889.1-M8-8-EP•Zn	Locknut	6
11	2000006103	G11006B15000-002	plate	2
12	3041600629	DIN316 M8X30	butterfly bolt	2
13	3080500007	GB/T93-8-EP•Zn	Spring washer	2
14	3060300004	GB/T70.2-M8×20-8.8-EP•Zn	Hexagon socket button head screws	4
15	3190100615	AD25-ID20	corrugated pipe	1
16	3130600020	Φ22	Lathedog	2
17	3060100005	GB/T70.1-M5×20-8.8-EP•Zn	Hexagon socket head cap screws	2
18	3080500005	GB/T93-5-EP•Zn	Spring washer	2
19	3080100002	GB/T95-5-EP•Zn	Plain washer	10
20	3050500001	GB/T889.1-M5-8-EP•Zn	Locknut	4

# Warranty

MANUFACTURER warrants to the original purchaser that this product will be free from defects in material and workmanship beginning on the date of purchase by the end user according to the following schedule when used as intended and under normal service and conditions for personal use.

**Overall Unit and Driveline:** 2 years Parts and Labor

**Blades and Belts:** Consumable part

This Warranty is limited to the replacement of any defective part by MANUFACTURER and the installation by the dealer of any such replacement part, and does not cover common wear items. MANUFACTURER reserves the right to inspect any equipment or parts which are claimed to have been defective in material or workmanship.

This Warranty does not apply to any part or product which in MANUFACTURER's judgment shall have been misused or damaged by accident or lack of normal maintenance or care, or which has been repaired or altered in a way which adversely affects its performance or reliability, or which has been used for a purpose for which the product is not designed. Misuse also specifically includes failure to properly maintain oil levels, grease points, and drive-line shafts.

Claims under this Warranty should be made to the dealer which originally sold the product and all warranty adjustments must be made through an authorized MANUFACTURER dealer. MANUFACTURER reserves the right to make changes in materials or design of the product at any time without notice.

This Warranty shall not be interpreted to render MANUFACTURER liable for damages of any kind, direct, consequential, or contingent to property. Furthermore, MANUFACTURER shall not be liable for damages resulting from any cause beyond its reasonable control. This Warranty does not extend to loss of crops, any expense or loss for labor, supplies, rental machinery or for any other reason.

**No other warranty of any kind whatsoever, express or implied, is made with respect to this sale; and all implied warranties of merchant-ability and fitness for a particular purpose which exceed the obligations set forth in this written warranty are hereby disclaimed and excluded from this sale.**

Fauna  
master<sup>®</sup>  
FLAIL MOWER

Faunamaster ApS · Tårnvej 32 · VAT No. DK42053767  
Phone +45 61404080 · Web: [www.faunamaster.com](http://www.faunamaster.com) · Mail: [sales@faunamaster.com](mailto:sales@faunamaster.com)